

PRELIMINARY

#	AMENDMENT	DATE

LEGEND

GREEN LINE
PREVIOUS VCAT HEARING PLANS REV'D 13.05.19

ORANGE LINE
AMENDED PLANS ASSESSED BY COUNCIL DATED 16.09.20

PACE OF MOUNT WAVERLEY
554-556 HIGH STREET ROAD
MOUNT WAVERLEY, VIC 3149

DRAWING:
PROPOSED BASEMENT 02 PLAN

Contractors must verify all dimensions on site before commencing any work or preparing shop drawings.
© COPYRIGHT

NORTH

CREATION DATE:
22.10.2021

JOB NO:
0057

SCALES:
1:100 @A0

AUTHOR:
AC

PACE

Pace Development Group Pty Ltd
Level 2, 201 Fitzroy Street
St Kilda VIC 3182
AON 31 100 448 817
P | +613 1200 722 324 F | +613 9992 1333

DRAWING NO:
A-TP-103

REV:

ISSUE DATE:
29/04/2022 9:27:58 AM

#	AMENDMENT	DATE

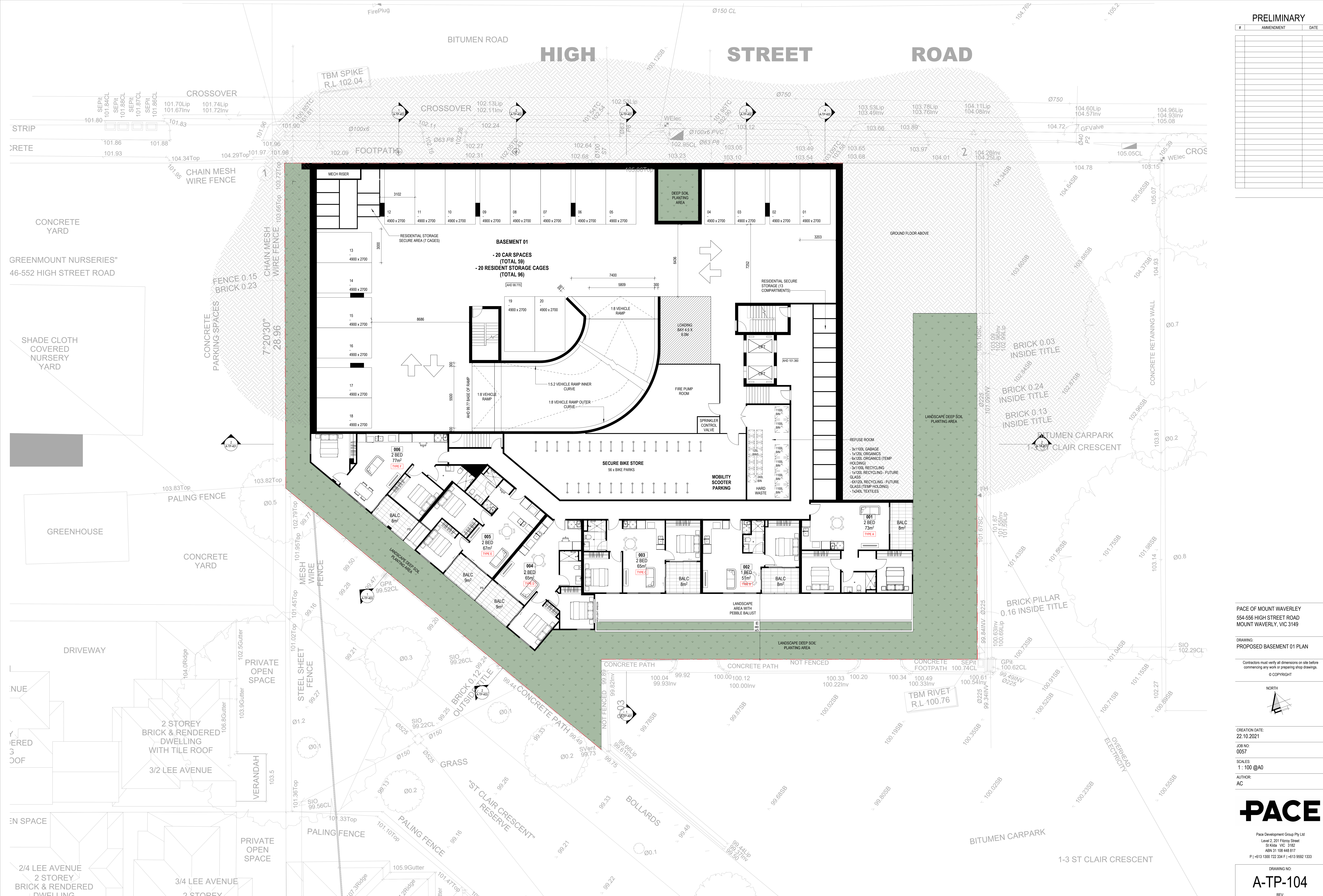

PACE
 Pace Development Group Pty Ltd
 Level 2, 201 Fitzroy Street
 St Kilda VIC 3182
 ABN 31 108 448 817
 P | +613 1200 722 324 F | +613 9992 1333

CREATION DATE: 22.10.2021
 JOB NO: 0057
 SCALES: 1:100 @A0
 AUTHOR: AC

PACE
 Pace Development Group Pty Ltd
 Level 2, 201 Fitzroy Street
 St Kilda VIC 3182
 ABN 31 108 448 817
 P | +613 1200 722 324 F | +613 9992 1333

ISSUE DATE: 29/04/2022 9:28:02 AM

DRAWING NO:
A-TP-104
 REV:
 ISSUE DATE:
 29/04/2022 9:28:02 AM

PACE OF MOUNT WAVERLEY
 554-556 HIGH STREET ROAD
 MOUNT WAVERLEY, VIC 3149

DRAWING:
PROPOSED BASEMENT 01 PLAN

Contractors must verify all dimensions on site before commencing any work or preparing shop drawings.
 © COPYRIGHT

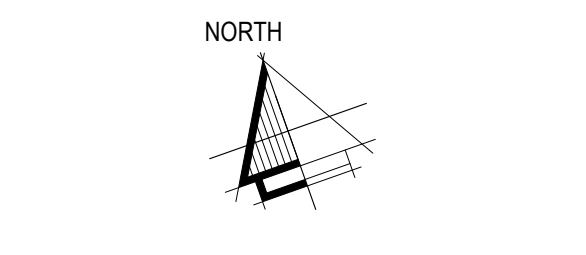

CREATION DATE: 22.10.2021
 JOB NO: 0057
 SCALES: 1:100 @A0
 AUTHOR: AC

PACE
 Pace Development Group Pty Ltd
 Level 2, 201 Fitzroy Street
 St Kilda VIC 3182
 ABN 31 108 448 817
 P | +613 1200 722 324 F | +613 9992 1333

DRAWING NO:
A-TP-104
 REV:
 ISSUE DATE:
 29/04/2022 9:28:02 AM

PRELIMINARY

#	AMENDMENT	DATE



PACE OF MOUNT WAVERLEY
554-556 HIGH STREET ROAD
MOUNT WAVERLEY, VIC 3149

DRAWING:
PROPOSED GROUND FLOOR PLAN

Contractors must verify all dimensions on site before commencing any work or preparing shop drawings.
© COPYRIGHT

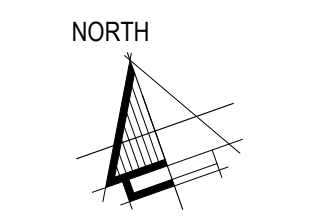

CREATION DATE:
22.10.2021

JOB NO:
0057

SCALE:
1 : 100 @A0

AUTHOR:
AC

PACE

Pace Development Group Pty Ltd
Level 2, 201 Fitzroy Street
St Kilda VIC 3182
AEN 31 108 448 817
PJ +613 1200 722 334 FJ +613 9992 1333

DRAWING NO:
A-TP-105

REV:

ISSUE DATE:
29/04/2022 9:28:07 AM

#	AMENDMENT	DATE



PACE OF MOUNT WAVERLEY
 554-556 HIGH STREET ROAD
 MOUNT WAVERLEY, VIC 3149

DRAWING:
 PROPOSED LEVEL 01 PLAN

Contractors must verify all dimensions on site before commencing any work or preparing shop drawings.
 © COPYRIGHT

CREATION DATE:
 22.10.2021

JOB NO:
 0057

SCALES:
 1:100 @A0

AUTHOR:
 AC

NORTH

PACE

Pace Development Group Pty Ltd
 Level 2, 201 Fitzroy Street
 St Kilda VIC 3182
 ABN 31 108 448 817
 P | +61 3 1200 722 334 F | +61 3 992 1333

DRAWING NO:
A-TP-106

REV:

ISSUE DATE:
 29/04/2022 9:28:12 AM

Table with 3 columns: #, AMENDMENT, DATE. It contains a grid for recording revisions.



PACE OF MOUNT WAVERLEY
554-556 HIGH STREET ROAD
MOUNT WAVERLEY, VIC 3149

DRAWING:
PROPOSED LEVEL 02 PLAN

Contractors must verify all dimensions on site before commencing any work or preparing shop drawings. © COPYRIGHT

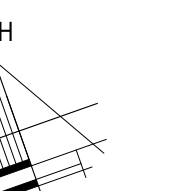

CREATION DATE:
22.10.2021

JOB NO:
0057

SCALES:
1:100 @A0

AUTHOR:
AC

PACE

Pace Development Group Pty Ltd
Level 2, 201 Fitzroy Street
St Kilda VIC 3182
A/N 31 508 448 817
P1 +613 1200 722 334 F1 +613 9592 1333

DRAWING NO:
A-TP-107

REV:

ISSUE DATE:
29/04/2022 9:28:18 AM

#	AMENDMENT	DATE



PACE OF MOUNT WAVERLEY
554-556 HIGH STREET ROAD
MOUNT WAVERLEY, VIC 3149

DRAWING:
PROPOSED LEVEL 03 PLAN

Contractors must verify all dimensions on site before commencing any work or preparing shop drawings.
© COPYRIGHT

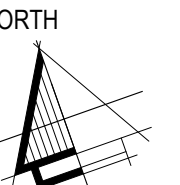

CREATION DATE:
22.10.2021

JOB NO:
0057

SCALES:
1: 100 @A0

AUTHOR:
AC

PACE

Pace Development Group Pty Ltd
Level 2, 201 Fitzroy Street
St Kilda VIC 3182
AEN 31 100 468 817

P | +613 1200 722 334 F | +613 9592 1333

DRAWING NO:
A-TP-108

REV:

ISSUE DATE:
29/04/2022 9:28:24 AM

PRELIMINARY

#	AMENDMENT	DATE



PACE OF MOUNT WAVERLEY
 554-556 HIGH STREET ROAD
 MOUNT WAVERLEY, VIC 3149

DRAWING:
 PROPOSED LEVEL 04 PLAN

Contractors must verify all dimensions on site before commencing any work or preparing shop drawings.
 © COPYRIGHT

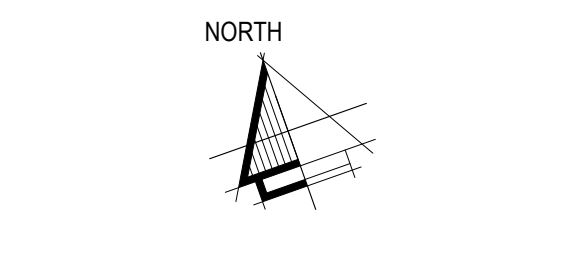

CREATION DATE:
 22.10.2021

JOB NO:
 0057

SCALE:
 1:100 @A0

AUTHOR:
 AC



Pace Development Group Pty Ltd
 Level 2, 201 Fitzroy Street
 St Kilda VIC 3182
 ABN 31 108 448 817
 P1 +61 3 1300 722 334 F1 +61 3 9592 1333

DRAWING NO:
A-TP-109
 REV:

ISSUE DATE:
 29/04/2022 9:28:29 AM

#	AMENDMENT	DATE



PACE OF MOUNT WAVERLEY
554-556 HIGH STREET ROAD
MOUNT WAVERLEY, VIC 3149

DRAWING:
PROPOSED LEVEL 05 PLAN

Contractors must verify all dimensions on site before commencing any work or preparing shop drawings. © COPYRIGHT

CREATION DATE:
22.10.2021

JOB NO:
0057

SCALE:
1:100 @A0

AUTHOR:
AC

PACE

Pace Development Group Pty Ltd
Level 2, 201 Fitzroy Street
St Kilda VIC 3182
A/N 31 108 448 817
P | +613 1200 722 334 F | +613 9992 1333

DRAWING NO:
A-TP-110

REV:

ISSUE DATE:
29/04/2022 9:28:37 AM

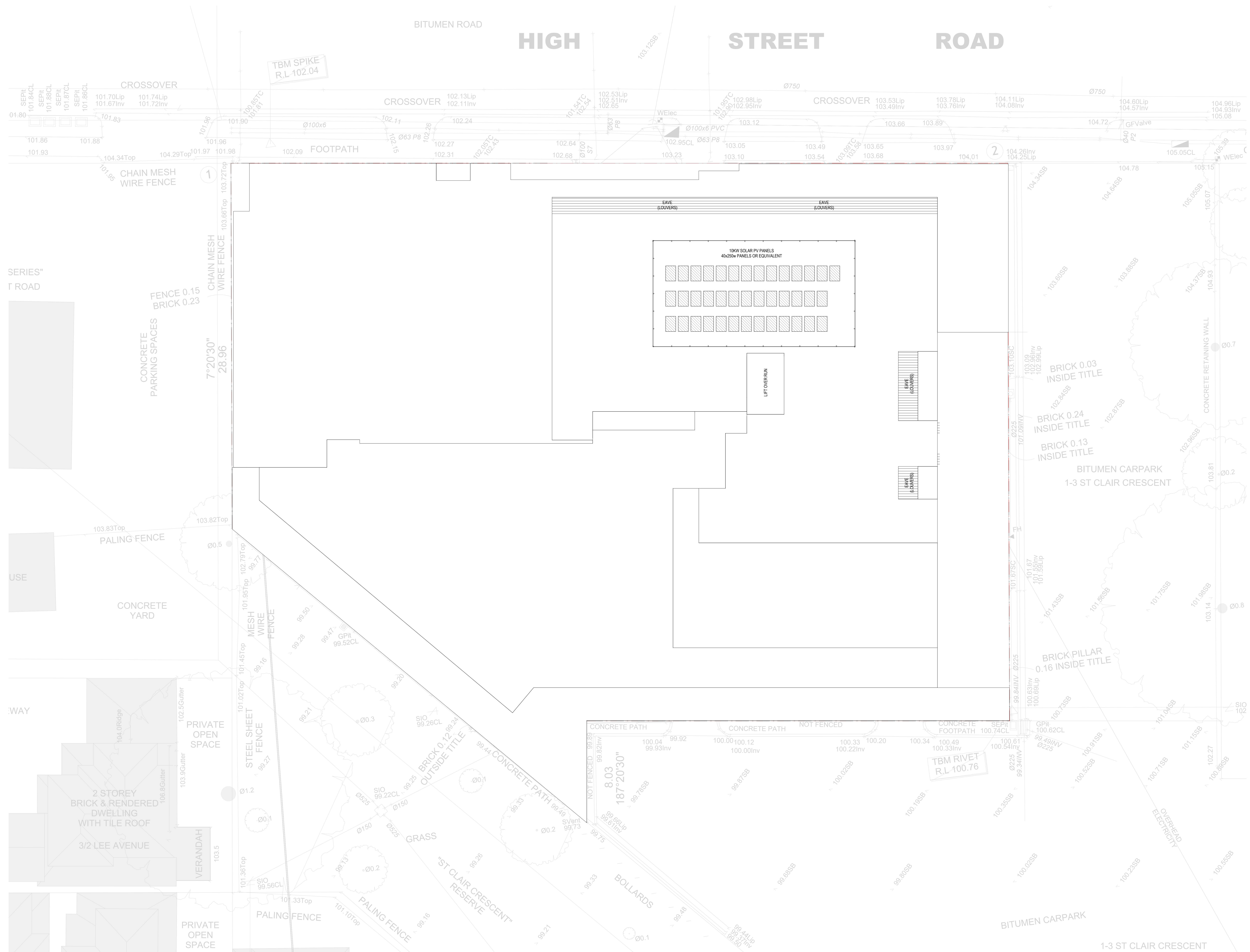

PACE OF MOUNT WAVERLEY
 554-556 HIGH STREET ROAD
 MOUNT WAVERLEY, VIC 3149

DRAWING:
 PROPOSED ROOF PLAN

Contractors must verify all dimensions on site before commencing any work or preparing shop drawings.
 © COPYRIGHT

NORTH

CREATION DATE:
 04/21/22

JOB NO:
 0057

SCALES:
 1:100 @A0

AUTHOR:
 Author

PACE

Pace Development Group Pty Ltd
 Level 2, 201 Fitzroy Street
 St Kilda VIC 3182
 ASN 31 100 448 817
 P | +61 3 1300 722 324 F | +61 3 9922 1333

DRAWING NO:
A-TP-4.04
 REV:

ISSUE DATE:
 29/04/2022 9:27:33 AM

#	AMMENDMENT	DATE



NORTH ELEVATION

MATERIAL LEGEND

- BR1 LIGHTWEIGHT FC CLADDING, TEXTURED PAINTED OFFWHITE
- BR2 LIGHTWEIGHT FC CLADDING, TEXTURED PAINTED CHARCOAL
- CN1 CONCRETE SLAB EDGE, TEXTURED PAINTED TO MATCH CLADDING COLOUR
- CN2 CONCRETE PANEL WITH VERTICAL PATTERN
- MC1 METAL CLADDING WITH VERTICAL PATTERN, PREFINISHED WHITE
- SB ALUMINUM FRAMED BALUSTRADE WITH PERFORATED PANEL INFILL, POWDERCOATED TO MATCH ADJACENT CLADDING COLOUR
- GB ALUMINUM FRAMED BALUSTRADE WITH TINTED GLASS INFILL
- AL ALUMINUM FEATURE FRAME & SCREEN, POWDERCOATED BLACK
- RE CONCRETE WALL, TEXTURED PAINTED CHARCOAL
- ... ALL EXTERNAL DOORS & WINDOWS TO BE ALUMINUM FRAMED POWDERCOATED CHARCOAL



EAST ELEVATION

PACE OF MOUNT WAVERLEY
 554-556 HIGH STREET ROAD
 MOUNT WAVERLEY, VIC 3149

DRAWING:
 NORTH + EAST ELEVATION

Contractors must verify all dimensions on site before commencing any work or preparing shop drawings.
 © COPYRIGHT

NORTH

CREATION DATE:
 22.10.2021

JOB NO:
 0057

SCALES:
 1 : 100 @A0

AUTHOR:
 AC

PACE

Pace Development Group Pty Ltd
 Level 2, 201 Fitzroy Street
 St Kilda VIC 3182
 ABN 31 100 448 817
 P | +61 3 1200 722 324 F | +61 3 9592 1333

DRAWING NO:
A-TP-300
 REV:

ISSUE DATE:
 29/04/2022 9:29:24 AM

#	AMENDMENT	DATE

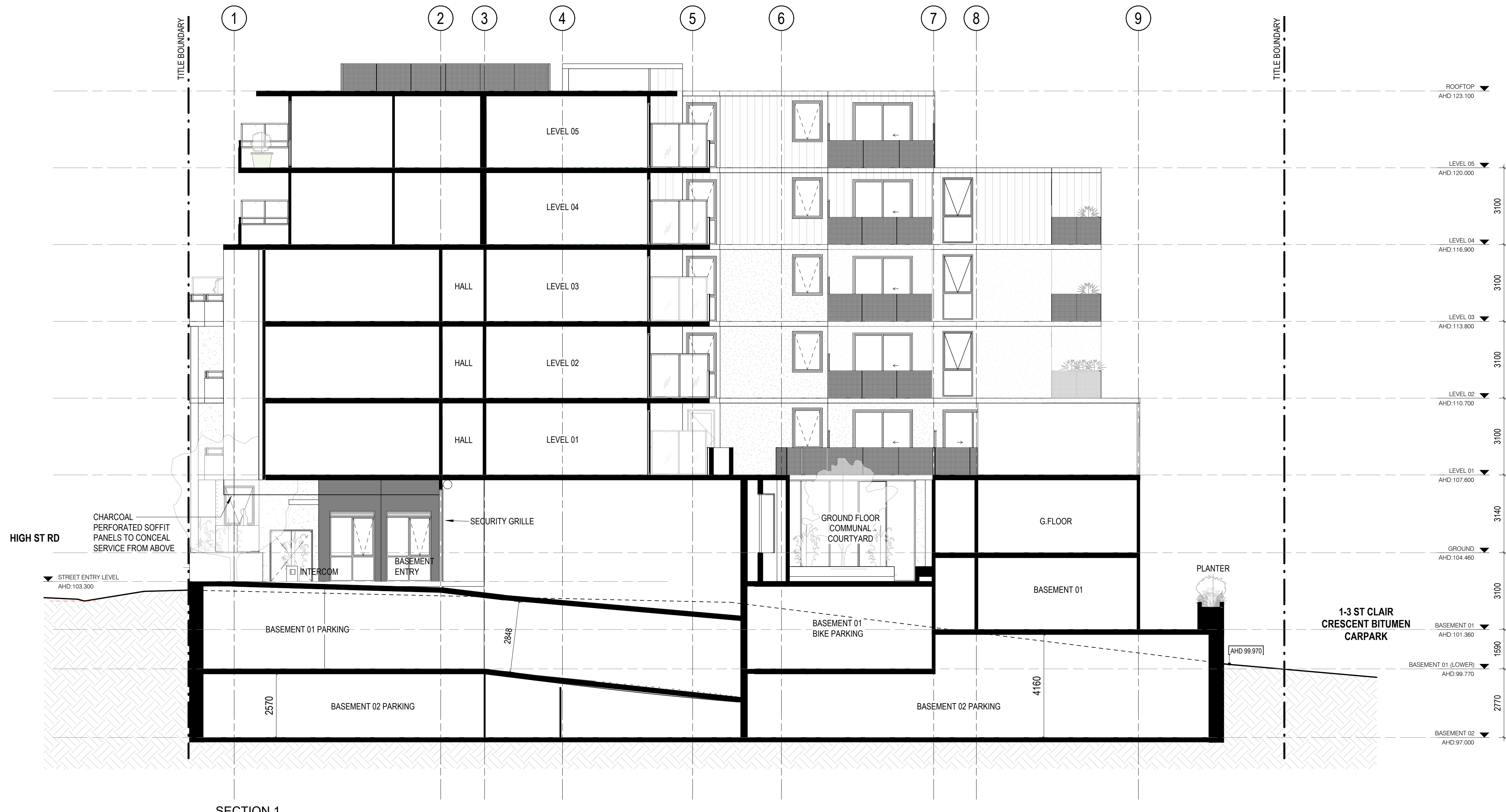

SECTION 1

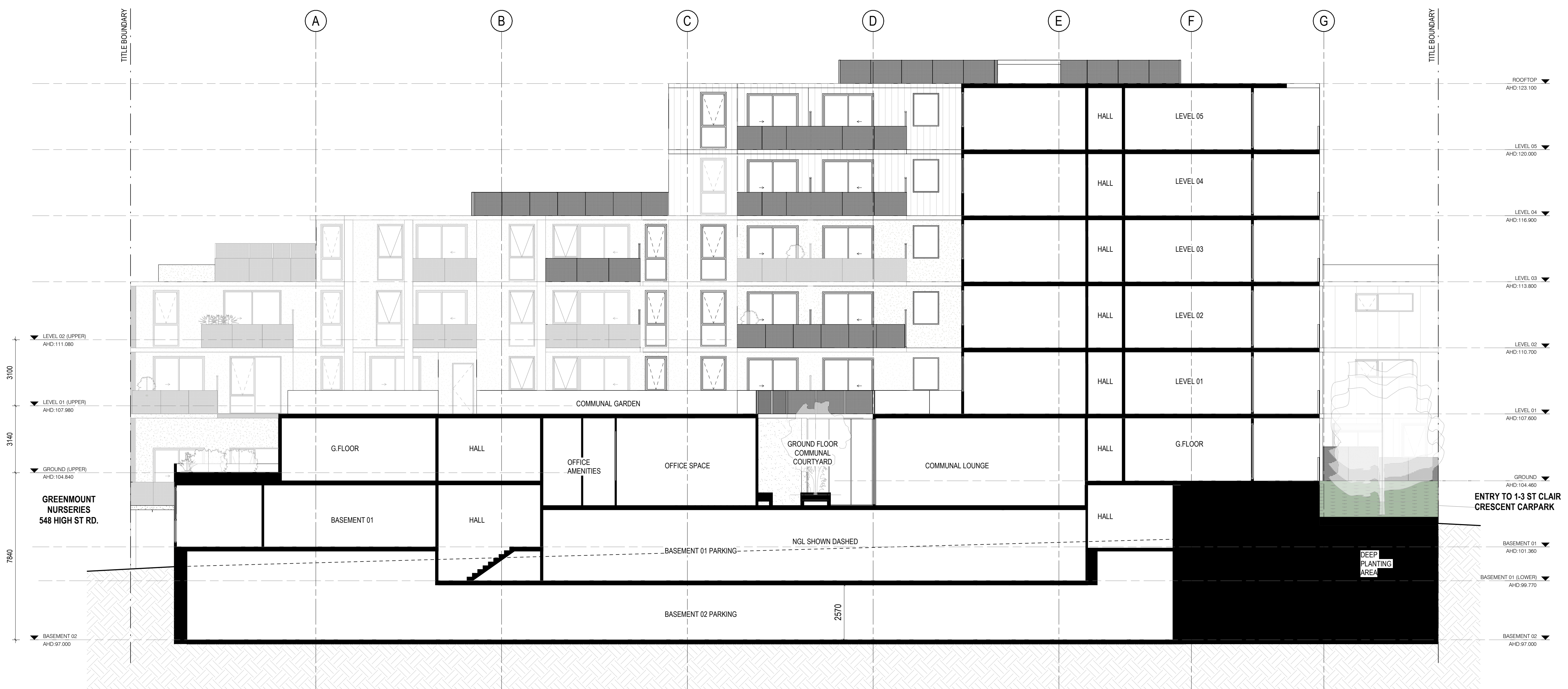

SECTION 2

PACE OF MOUNT WAVERLEY
554-556 HIGH STREET ROAD
MOUNT WAVERLEY, VIC 3149

DRAWING:
SECTIONS

Contractors must verify all dimensions on site before commencing any work or preparing shop drawings.
© COPYRIGHT

NORTH

CREATION DATE:
22.10.2021

JOB NO:
0057

SCALES:
1 : 100 @A0

AUTHOR:
AC



Pace Development Group Pty Ltd
Level 2, 201 Fitzroy Street
St Kilda VIC 3182
ABN 31 100 448 817
P | +613 1300 722 224 F | +613 9992 1333

DRAWING NO:
A-TP-401

REV:
F

ISSUE DATE:
29/04/2022 9:30:28 AM

EXTERNAL FINISHES

#	AMMENDMENT	DATE

MATERIAL SCHEDULE

BR1
LIGHTWEIGHT FC CLADDING, TEXTURED PAINTED TO MATCH BRICK COLOUR

BR2
LIGHTWEIGHT FC CLADDING, TEXTURED PAINTED CHARCOAL

CN1
CONCRETE SLAB EDGE, TEXTURED PAINTED TO MATCH CLADDING COLOUR

CN2
CONCRETE PANEL WITH VERTICAL PATTERN, PAINTED TO MATCH BRICK COLOUR

MC1
METAL CLADDING WITH VERTICAL PATTERN, PREFINISHED CHARCOAL

SB
STEEL BALUSTRADE WITH PERFORATED PANEL INFILL. POWDERCOATED TO MATCH ADJACENT CLADDING COLOUR

GB
SOLID BASE TO CATCH CLADDING, ALUMINIUM FRAMED BALUSTRADE WITH TINTED GLASS INFILL TOPPER

AL
ALUMINIUM FEATURE FRAME & SCREEN. POWDERCOATED BLACK

RE
BRICK INFILL - LIGHT GREY/BROWN

ALL EXTERNAL DOORS & WINDOWS TO BE ALUMINIUM FRAMED POWERCOATED CHARCOAL

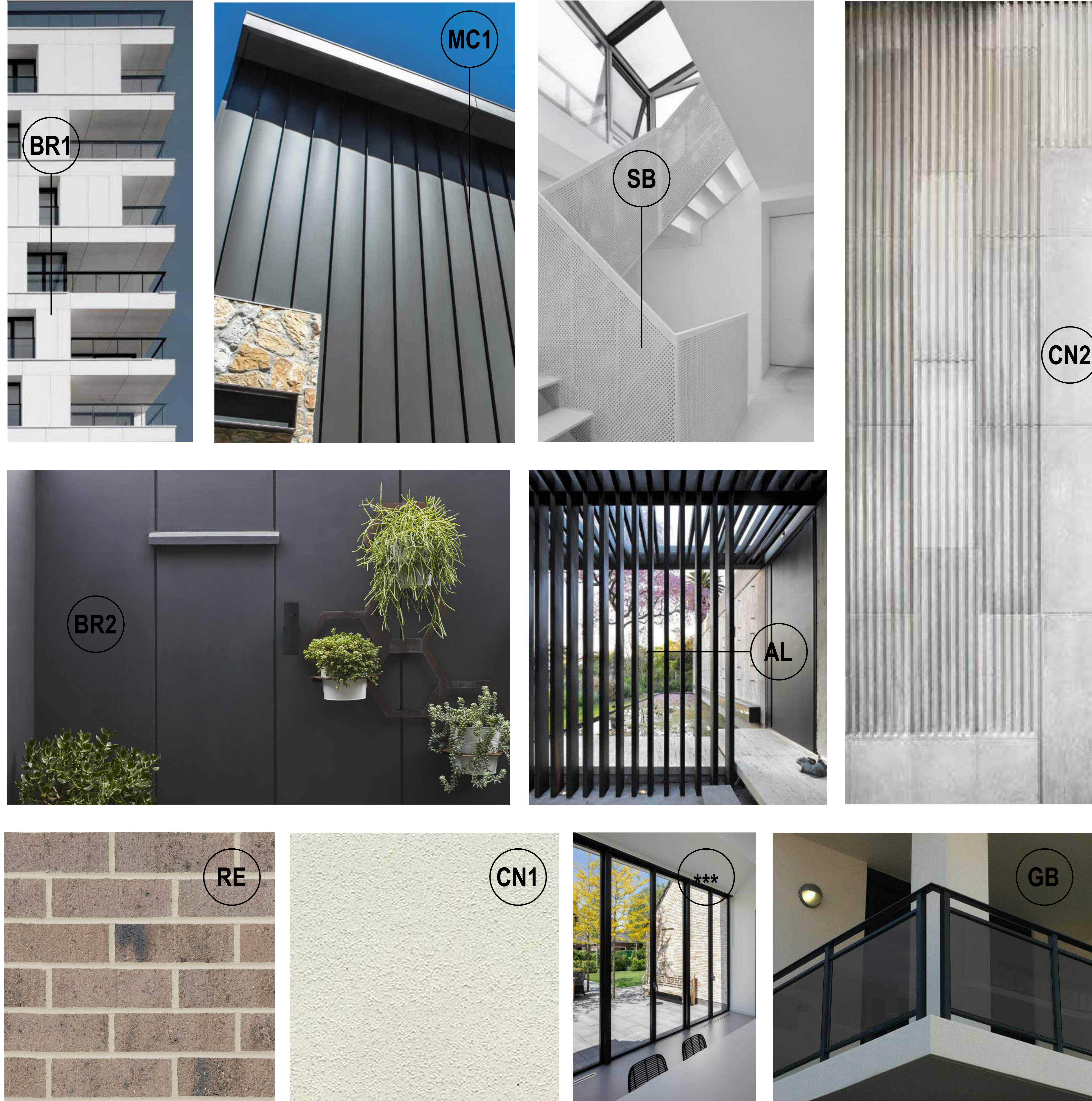

PACE OF MOUNT WAVERLEY
554-556 HIGH STREET ROAD
MOUNT WAVERLEY, VIC 3149

DRAWING:
MATERIAL SCHEDULE

Contractors must verify all dimensions on site before commencing any work or preparing shop drawings.
© COPYRIGHT

NORTH

CREATION DATE:
03.02.22

JOB NO:
0057

SCALES:
@A0

AUTHOR:
AC

PACE

Pace Development Group Pty Ltd
Level 2, 201 Fitzroy Street
St Kilda VIC 3182
AON 31 100 448 817
P | +613 1200 722 334 F | +613 9992 1333

DRAWING NO:
A-TP-4.00

REV:

ISSUE DATE:
29/04/2022 9:27:23 AM

#	AMENDMENT	DATE

HIGH STREET ROAD

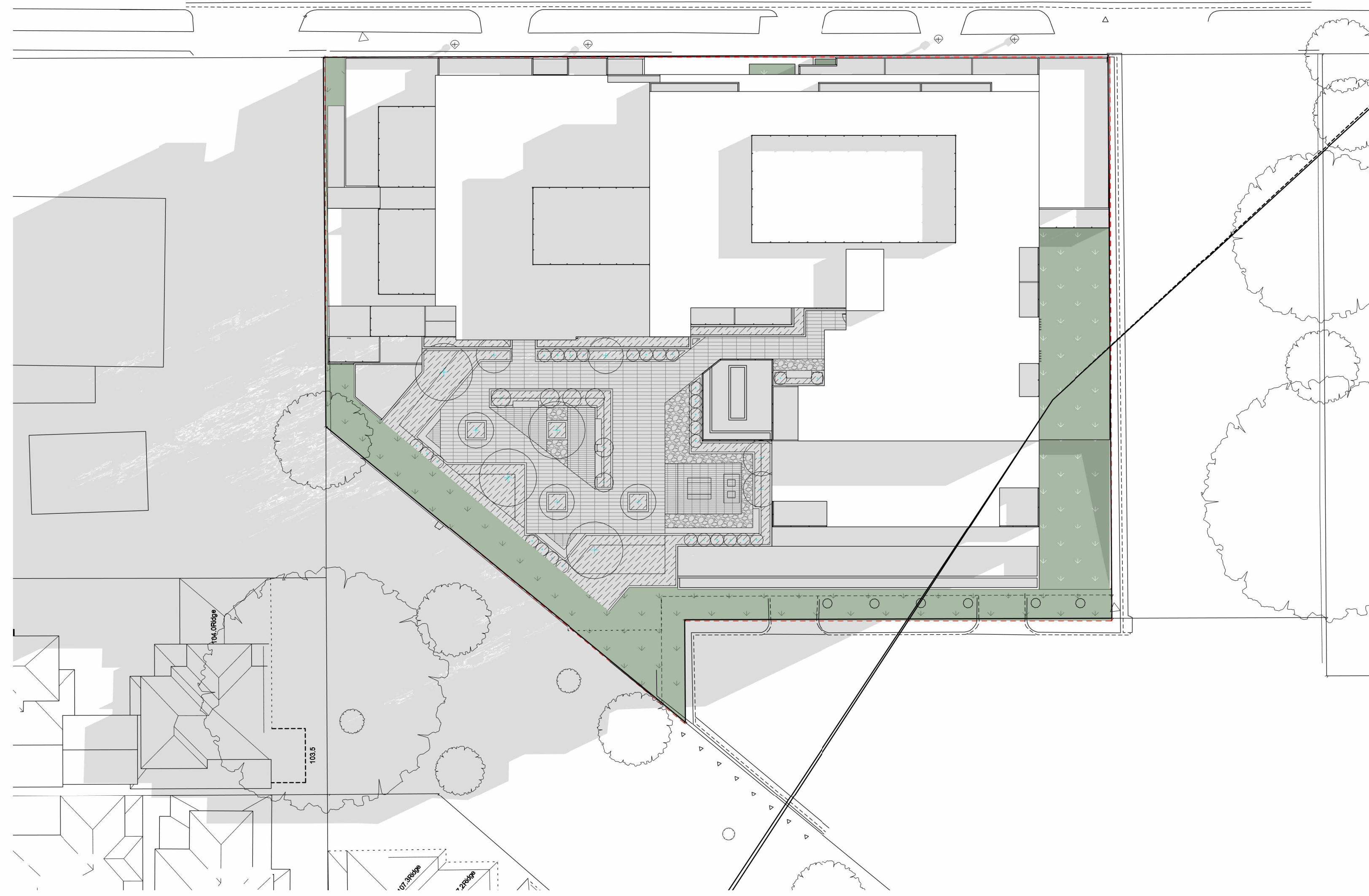

SHADOW - SEPT 22 - 9am
1:250

HIGH STREET ROAD

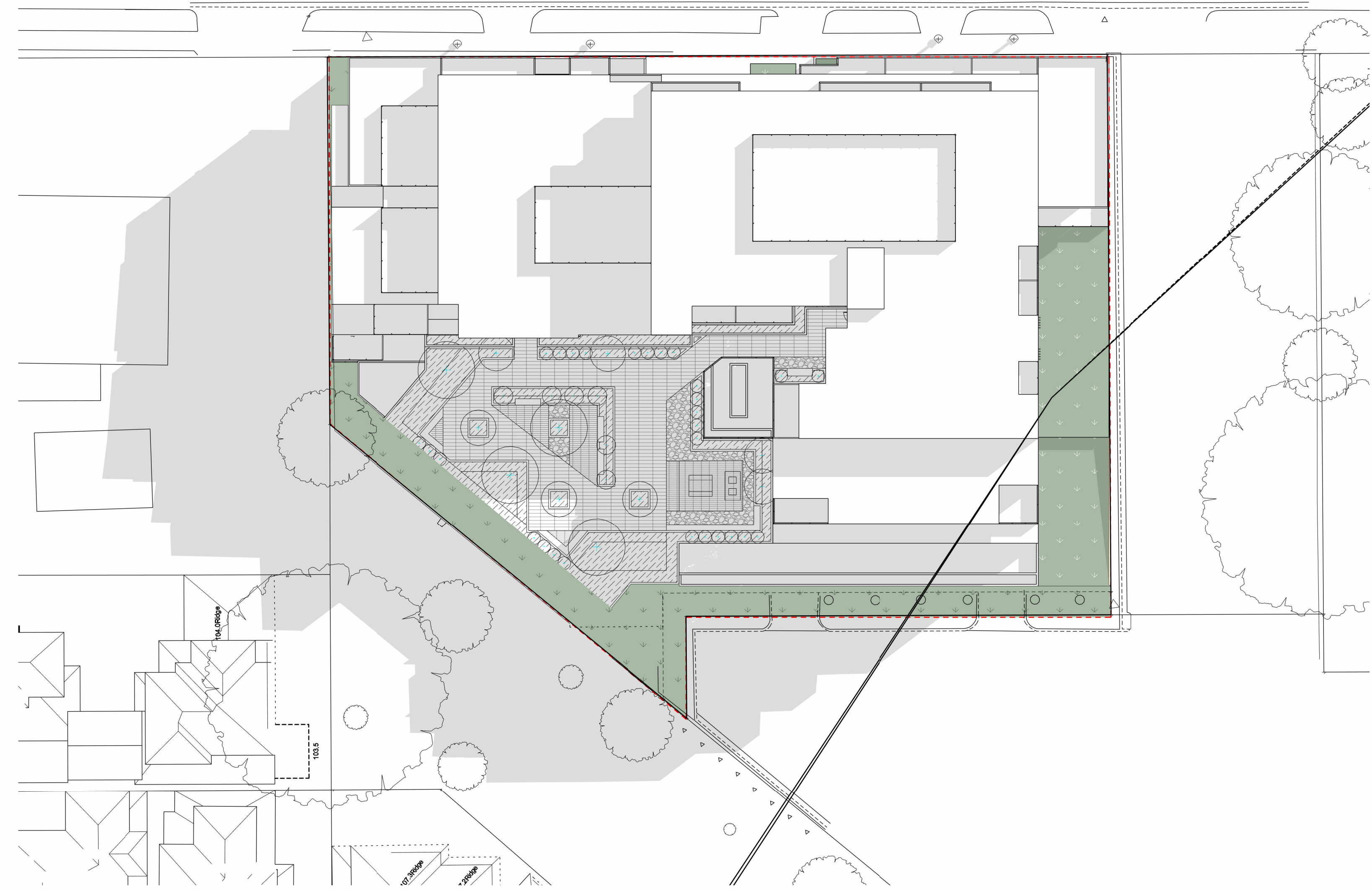

SHADOW - SEPT 22 - 10am
1:250

HIGH STREET ROAD

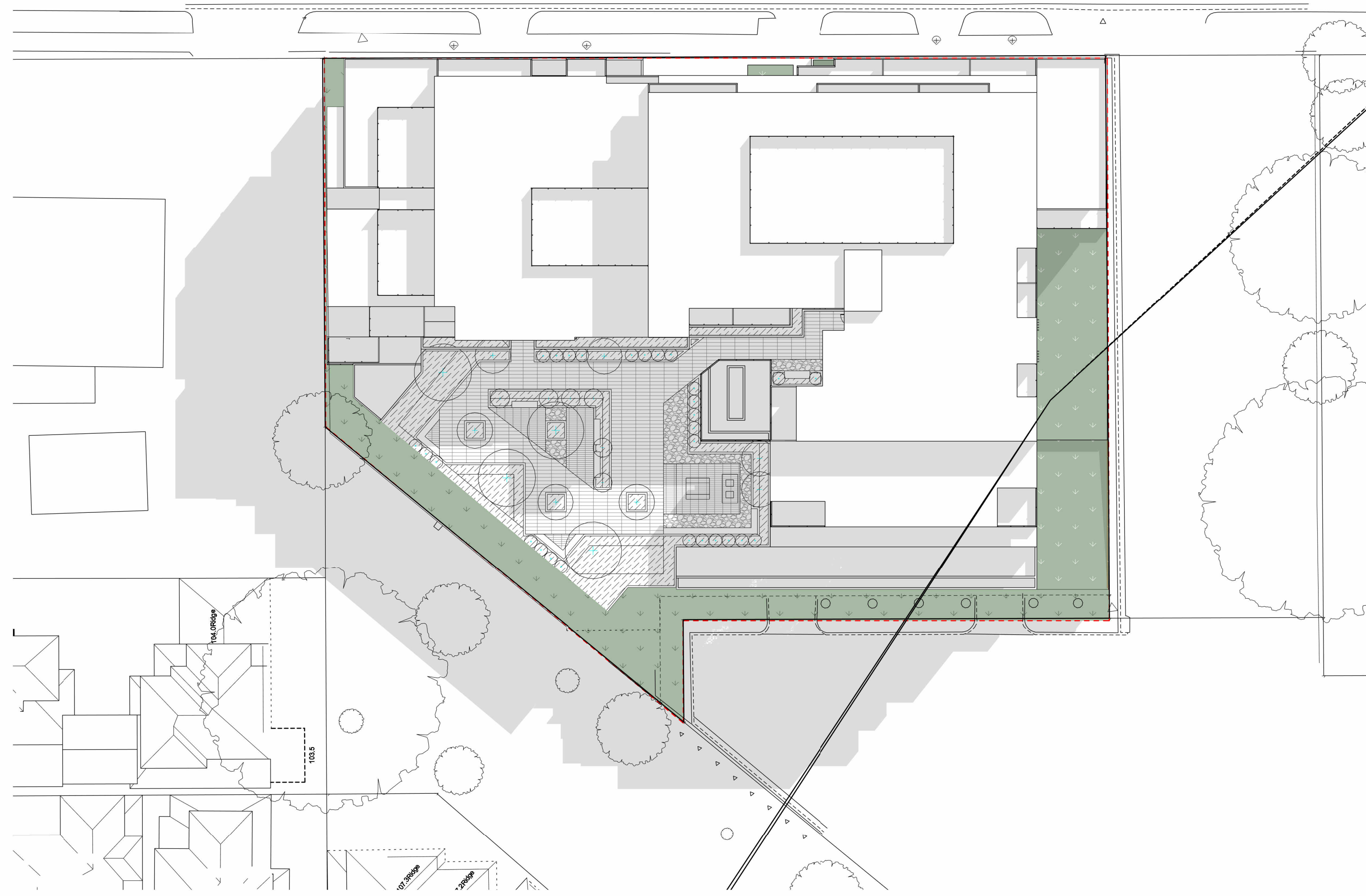

SHADOW - SEPT 22 - 11am
1:250

HIGH STREET ROAD

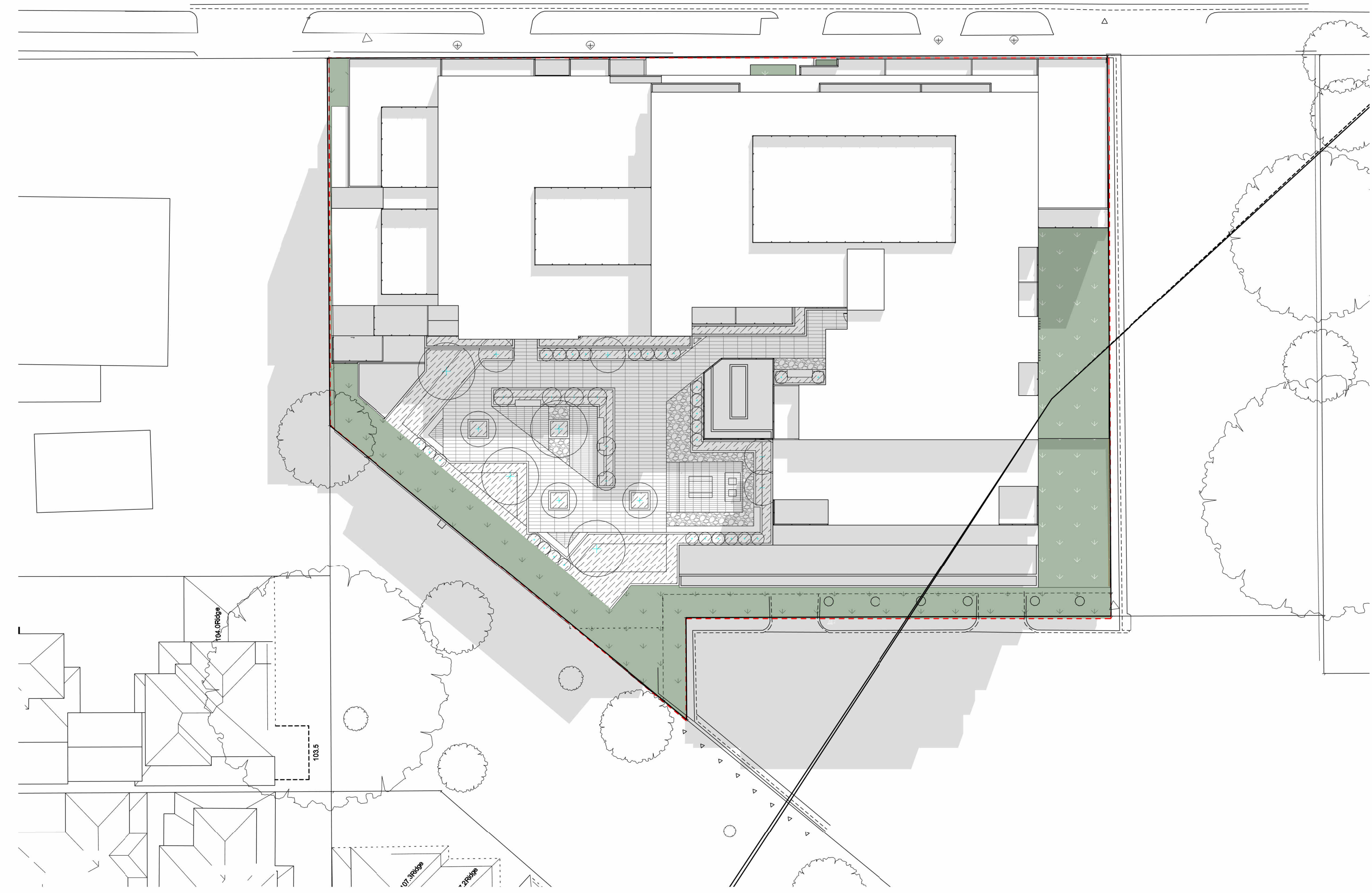

SHADOW - SEPT 22 - 12noon
1:250

PACE OF MOUNT WAVERLEY
554-556 HIGH STREET ROAD
MOUNT WAVERLEY, VIC 3149

DRAWING:
SHADOW DIAGRAMS
22 SEPTEMBER (SPRING EQUINOX)
Contractors must verify all dimensions on site before commencing any work or preparing shop drawings.
© COPYRIGHT

NORTH

CREATION DATE:
02/03/22

JOB NO:
0057

SCALES:
1:250 @A0

AUTHOR:
AC



Pace Development Group Pty Ltd
Level 2, 201 Fitzroy Street
St Kilda VIC 3182
AON 31 608 448 817
P | +613 1200 722 324 F | +613 9592 1333

DRAWING NO:

A-TP-500

REV:

ISSUE DATE:
29/04/2022 9:31:32 AM

#	AMENDMENT	DATE

HIGH STREET ROAD

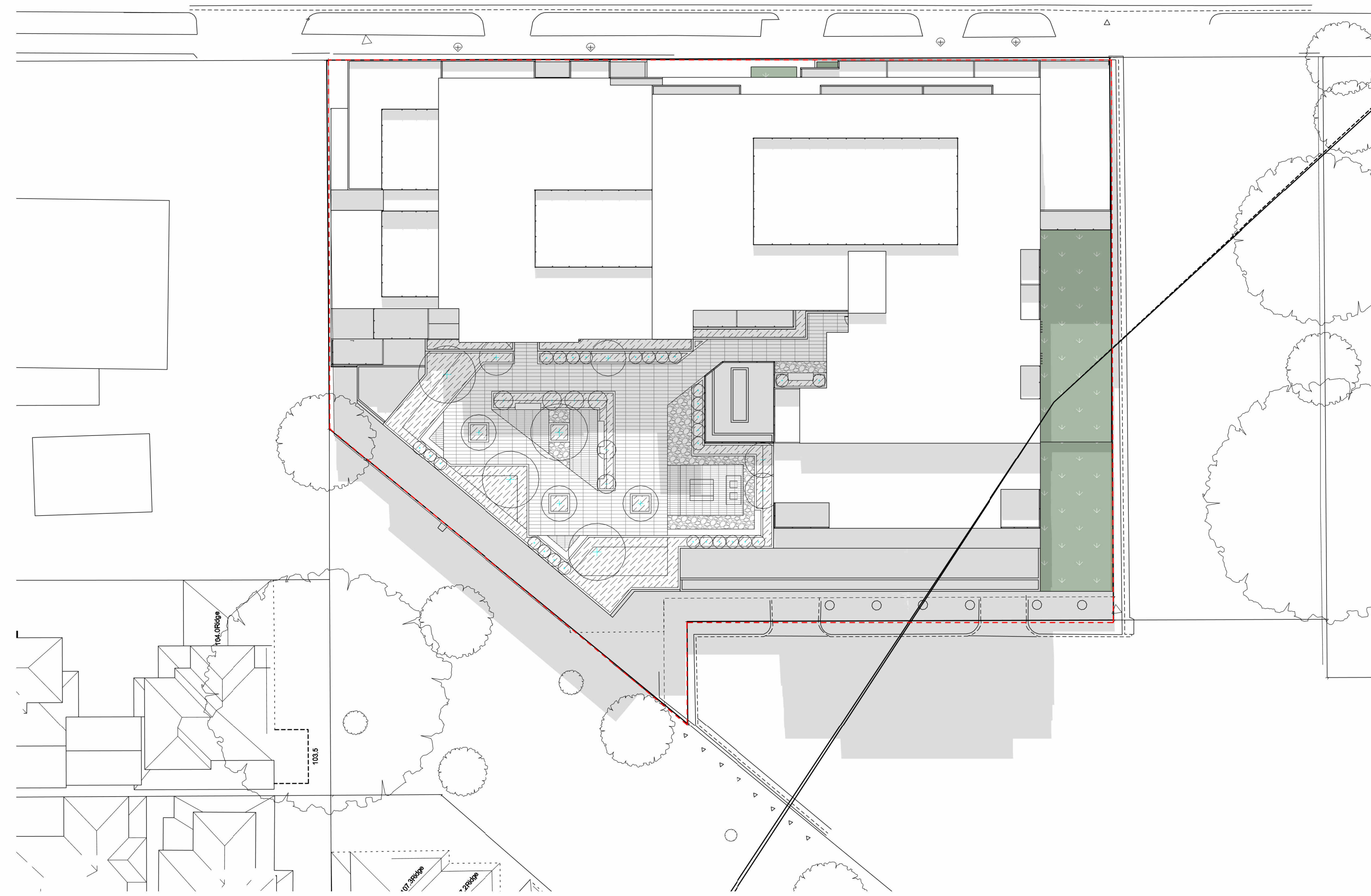

1 SHADOW - SEPT 22 - 1pm
1:250

HIGH STREET ROAD

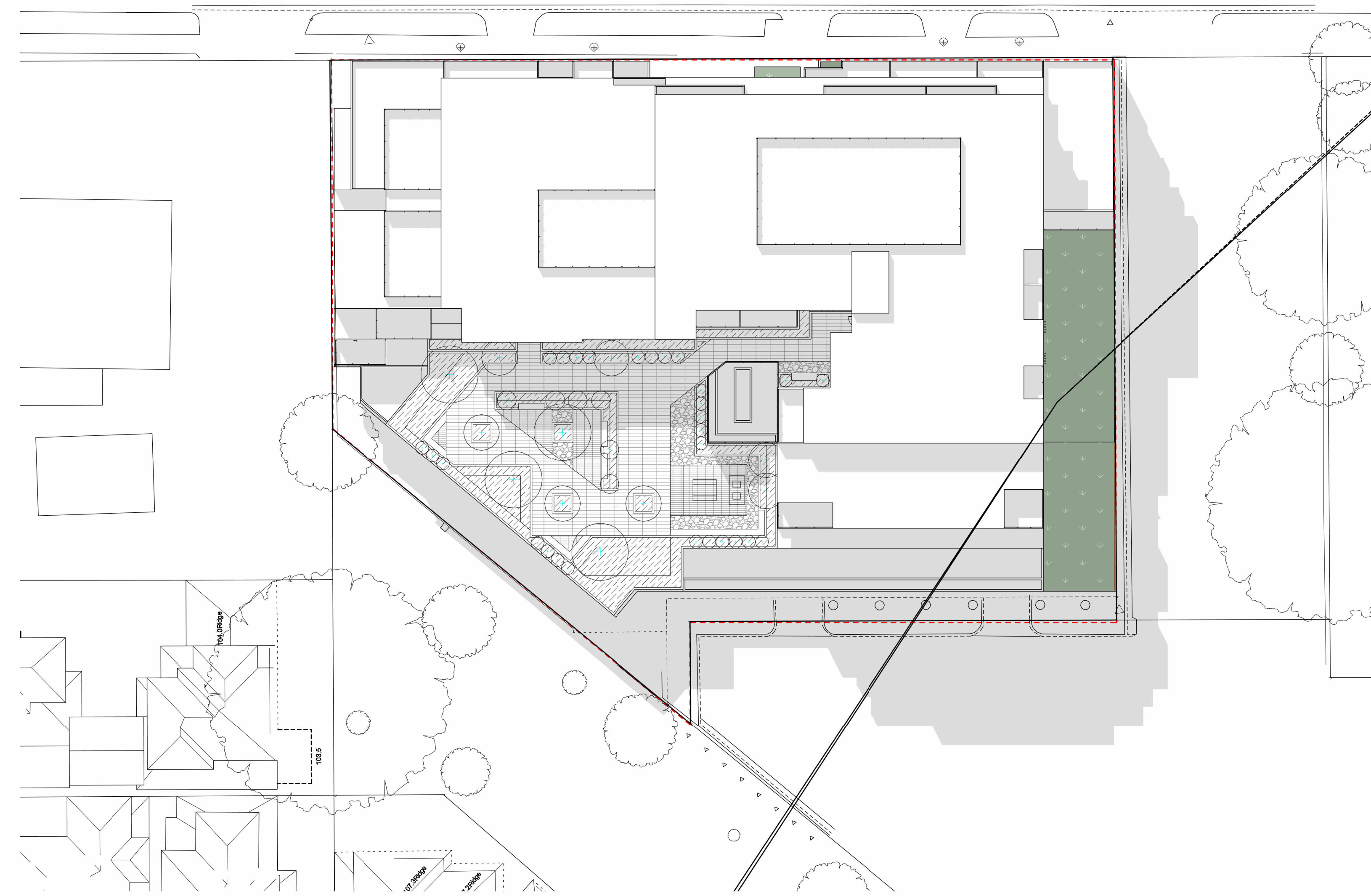

2 SHADOW - SEPT 22 - 2pm
1:250

HIGH STREET ROAD

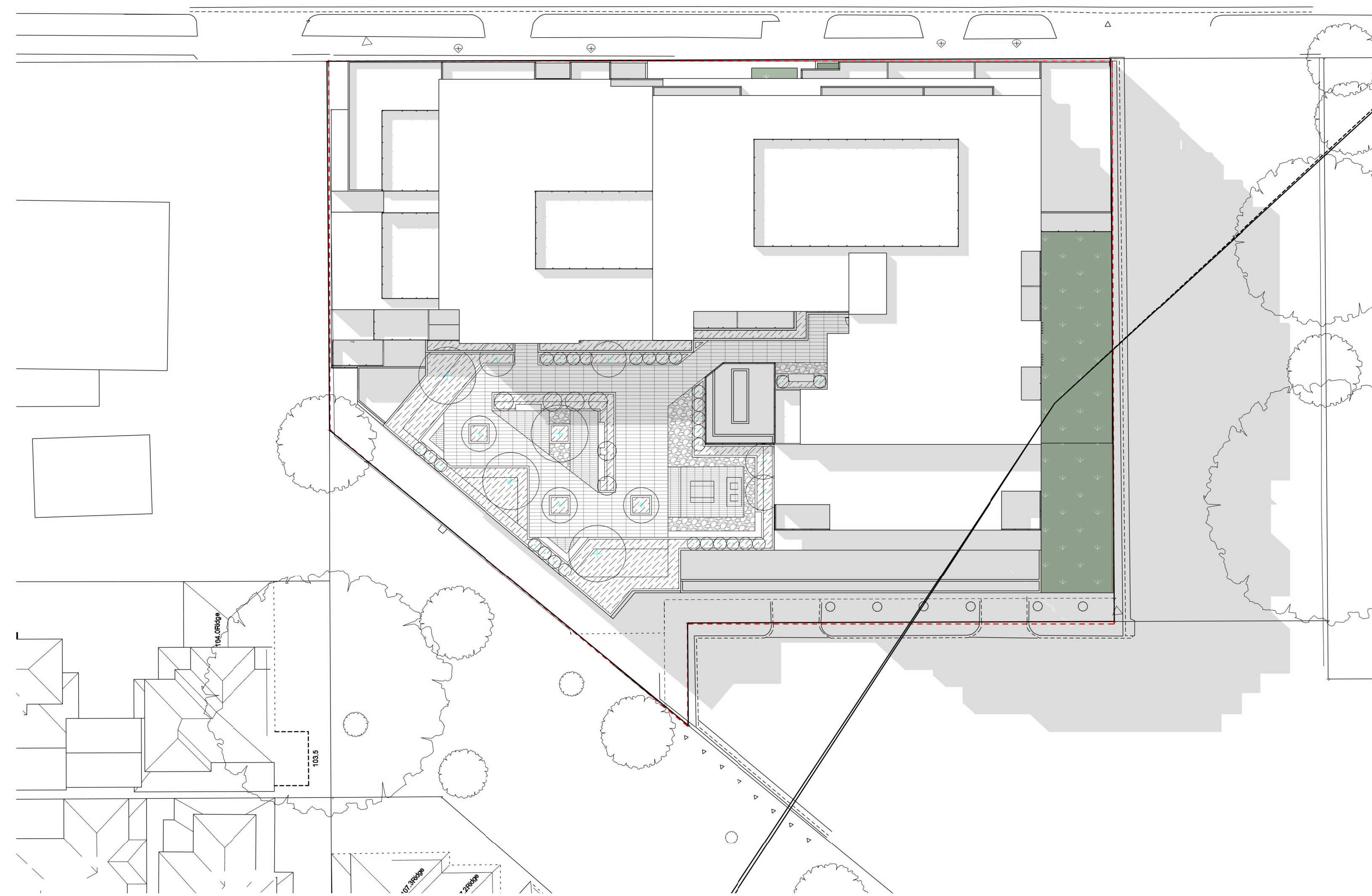

3 SHADOW - SEPT 22 - 3pm
1:250

PACE OF MOUNT WAVERLEY
554-556 HIGH STREET ROAD
MOUNT WAVERLEY, VIC 3149

DRAWING:
SHADOW DIAGRAMS
22 SEPTEMBER (SPRING EQUINOX)

Contractors must verify all dimensions on site before commencing any work or preparing shop drawings.
© COPYRIGHT

NORTH

CREATION DATE:
02/03/22

JOB NO:
0057

SCALES:
1:250 @A0

AUTHOR:
AC

PACE

Pace Development Group Pty Ltd
Level 2, 201 Fitzroy Street
St Kilda VIC 3182
A/N 31 100 448 817
P | +613 1200 722 324 F | +613 9992 1333

DRAWING NO:

A-TP-501

REV:

ISSUE DATE:
29/04/2022 9:32:22 AM

DEVELOPMENT SUMMARY

The proposal seeks to gain approval for 56 one bedroom units, 40 two bedroom units & 1 three bedroom unit, which results in a 58%-40% split between one and two bedroom units

Existing Details

Address
554-558 High Street Road, Mount Waverly

Site Area
2619sqm

Site Frontage
61.05m (High Street Road)
44.00m (St Clair Crescent)

Existing Building Type
Large Brick Sports Facility

Existing Building Use
Sports Facility
Car Dealership

PROJECT SUMMARY - APARTMENT AND PARKING								
LEVEL	1 BED - 1 BATH	2 BED - 1 BATH	3 BED - 2 BATH	TOTAL		CARPARK	STORAGE	BIKE PARK
L BASEMENT 02	-	-	-	-		39	69	
L BASEMENT 01	1	5	-	6		20	20	56
L GROUND	11	4	1	16				24
L 01	11	8	-	19				
L 02	11	8	-	19				
L 03	11	5	-	16				
L 04	7	4	-	11				
L 05	6	3	-	9				
SUBTOTAL	58	37	1	96		59	98	80
PERCENTAGE	60%	38%	2%					

PROJECT SUMMARY - AREAS					
LEVEL	LANDSCAPE / OUTDOOR COMMUNAL (m²)	NSA (m²) APARTMENT	TERRACE/BALCONY (m²)	GFA (m²) EX BALCONY & ROOF	NET-GROSS EFFICIENCY(NSA VS GFA)
L BASEMENT 02				1854	
L BASEMENT 01	450	398	50	1742	22%
L GROUND	233	1163	161	1881	61%
L 01	483	1142	163	1339	85%
L 02		1117	165	1296	86%
L 03		923	161	1075	85%
L 04		654	105	751	87%
L 05		535	83	626	85%
SUBTOTAL	1166	5932	888	10564	

PACE OF MOUNT WAVERLEY
554-556 HIGH STREET ROAD
MOUNT WAVERLY, VIC 3149

DRAWING:
DEVELOPMENT SUMMARY

Contractors must verify all dimensions on site before commencing any work or preparing shop drawings.
© COPYRIGHT

NORTH

CREATION DATE:
22.10.2021

JOB NO:
0057

SCALES:
1 : 100 @A0

AUTHOR:
AC

PACE

Pace Development Group Pty Ltd
Level 2, 201 Fitzroy Street
St Kilda VIC 3182
AON 31 100 448 817
P | +613 1200 722 324 F | +613 9992 1333

DRAWING NO:

TP-0.00

REV:

ISSUE DATE:
29/04/2022 9:33:13 AM



GROUND FLOOR

LEGEND:

- PROPOSED STREET TREE TO COUNCIL APPROVAL
- EXISTING TREE IN RESERVE
- PROPOSED TREE IN MULCHED AND IRRIGATED GARDEN BEDS REFER TO SUGGESTED PLANT SCHEDULE
- PROPOSED TREE IN MULCHED AND IRRIGATED GARDEN BEDS REFER TO SUGGESTED PLANT SCHEDULE
- PROPOSED TREE IN MULCHED AND IRRIGATED GARDEN BEDS REFER TO SUGGESTED PLANT SCHEDULE
- PROPOSED TREE IN MULCHED AND IRRIGATED GARDEN BEDS REFER TO SUGGESTED PLANT SCHEDULE
- PROPOSED TREE IN MULCHED AND IRRIGATED GARDEN BEDS REFER TO SUGGESTED PLANT SCHEDULE
- PROPOSED HEDGING IN MULCHED AND IRRIGATED GARDEN BEDS REFER TO SUGGESTED PLANT SCHEDULE
- PROPOSED PLANTING IN MULCHED AND IRRIGATED GARDEN BEDS REFER TO SUGGESTED PLANT SCHEDULE
- PROPOSED CLIMBERS IN MULCHED AND IRRIGATED GARDEN BEDS REFER TO SUGGESTED PLANT SCHEDULE
- PROPOSED OVERLAND FLOW GRAVEL SWALE TO FUTURE DETAIL
- PROPOSED ARTIFICIAL TURF TO FURTHER DETAIL
- PROPOSED MULCH TO FURTHER DETAIL
- PROPOSED PLANTERS TO FUTURE DETAIL
- PROPOSED BLUESTONE PAVING OR SIMILAR TO FUTURE DETAIL
- PROPOSED CONCRETE OR SIMILAR TO FUTURE DETAIL
- PEBBLES FINISH TO ARCHITECT'S DETAILS

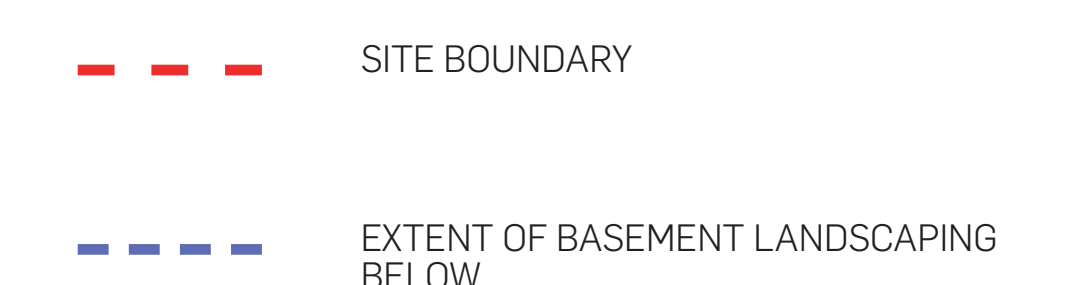

PLANT SCHEDULE

Code	Botanical Name	Common name	Size at maturity (HxW)	Pot / Installation size	Qty
TREES					
ACE pal	<i>Acer palmatum</i> 'Villa Taranto'	Villa Taranto Maple	3m x 3m	45L / 1.8m	3
BET pen	<i>Betula pendula</i> 'Moss White'	Moss White Birch	10m x 5m	45L / 1.8m	8
CIT lim	<i>Citrus x limon</i> 'Meyer'	Meyer Lemon	3m x 2m	45L / 1.8m	4
EUC mel	<i>Eucalyptus melliodora</i>	Yellow Box	10-30m x 8-20m	45L / 1.8m	2
LAG ind	<i>Lagerstroemia indica</i> 'Luscariosa'	Crape Myrtle	5-15m x 4-7m	45L / 1.8m	4
PYR ca	<i>Pyrus calleryana</i> 'Capital'	Capital Pear	11m x 3m	45L / 1.8m	7
PYR fr	<i>Pyrus calleryana</i> 'Frontier'	Frontier Pear	10m x 4m	45L / 1.8m	13
SYZ aus	<i>Syzygium australe</i> 'Pinnacle'	Brush Cherry	5m x 1.5m	45L / 1.8m	49
TRI lus	<i>Tristanopsis laurina</i> 'Luscious'	Kanooka Gum	8m x 4m	45L / 1.8m	6
SUBTOTAL					96
SHRUBS					
AZA alb	<i>Azalea</i> 'Alba Magnifica'	Alba Magnifica Azalea	1.4m x 1m	200mm/0.4x0.3m	28
CYC rev	<i>Cycas revoluta</i>	Sago Palm	1m x 1m	200mm/0.3x0.3m	6
GROUNDCOVERS & GRASSES					
ADJ rep	<i>Alysicarpus</i> 'Cattlin's Giant'	Cattlin's Giant Bugleweed	Groundcover	140mm/0.2x0.3m	377
DIC rep	<i>Dichondra repens</i>	Kidneyweed	0.1x 1m	140mm/0.1x0.2m	334
ROS off	<i>Rosmarinus officinalis</i> 'Prostratus'	Prostrate Rosemary	Groundcover/Cascading	140mm/0.2x0.3m	539
LOM lon	<i>Lomandra longifolia</i>	Spiny-Headed Mat-Rush	1m x 1.5m	140mm/0.5x0.3m	161
DIC sil	<i>Dichondra argentea</i> 'Silver Falls'	Silver Falls	Groundcover/Cascading	140mm/0.1x0.2m	34
ART or	<i>Arthropodium ornatum</i>	New Zealand Rock Lily	0.75m x 0.75m	140mm/0.2x0.3m	67
CCN one	<i>Comolobus cneorum</i>	Silver Bush	0.4m x 0.4m	140mm/0.2x0.2m	796
HED can	<i>Hedera canariensis</i>	Algerian Ivy	Spreading	140mm/0.2x0.4m	28
CLIMBERS					
FIG pum	<i>Ficus pumila</i>	Climbing Fig	Self-clinging climber	140mm/0.1x0.3m	173

Note - * indicate selected from 10.C Street Tree Planning List in Street Tree Strategy 2016 by City of Monash

PLANTING DETAILS

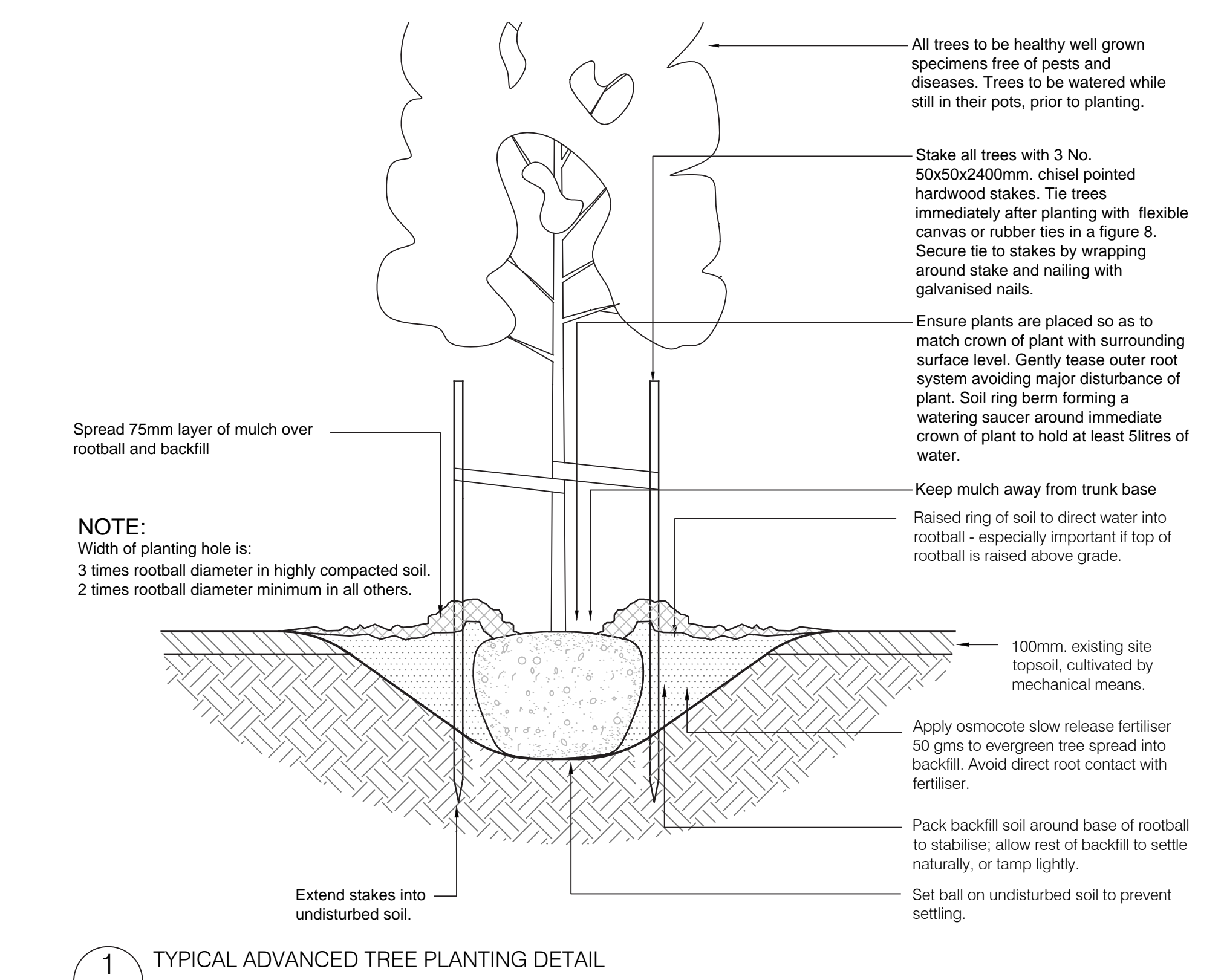

Shrub Planting Notes:
 1. Dig hole twice as deep as rootball and allow at least 200 mm. around sides for backfilling with topsoil.
 2. Apply fertiliser in base of hole, cover with topsoil (type & rate as per spec). Avoid root contact.
 3. Place plant in centre of hole, backfill with approved topsoil, firm progressively.
 4. Water well into saucer around crown of plant.
 5. Stake larger shrubs where necessary, using 50 x 50 x 1200 mm. hardwood stakes.

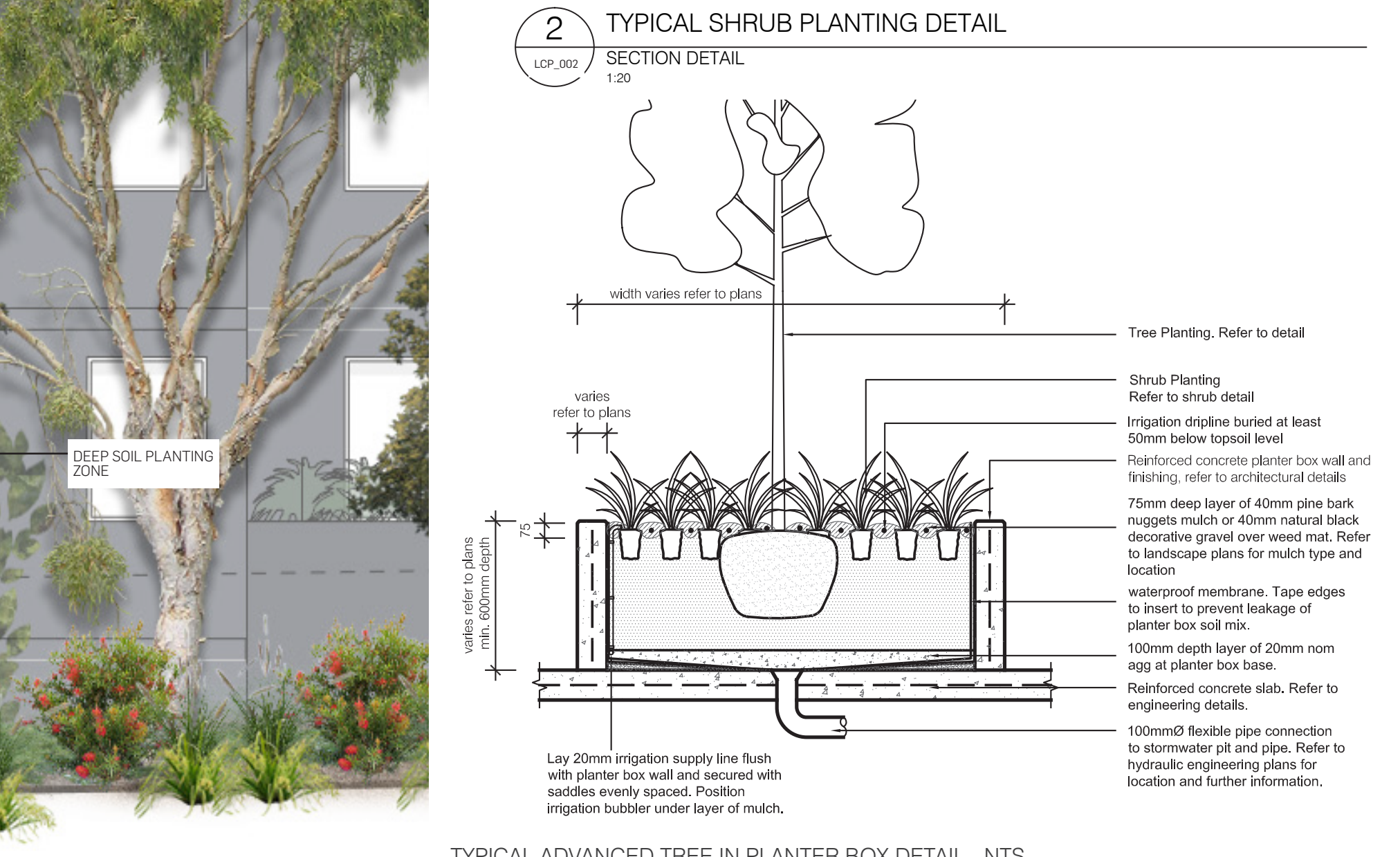
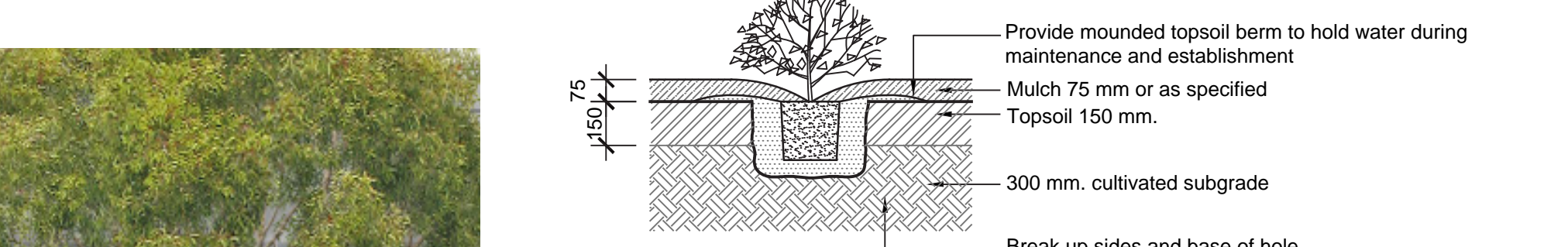

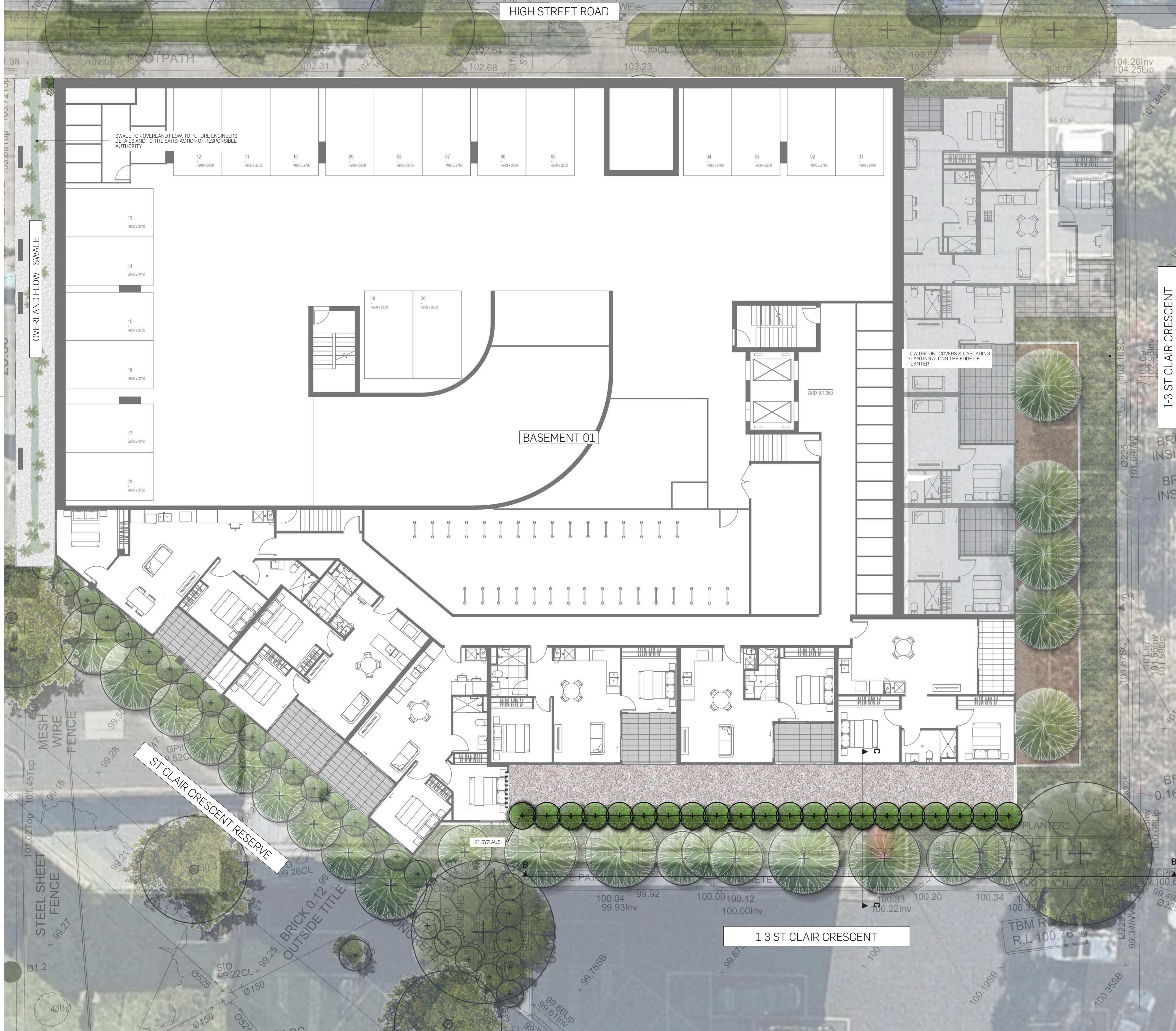

BASEMENT 01



FIRST FLOOR



INDICATIVE ELEVATION (BB) OF LANDSCAPE BUFFER

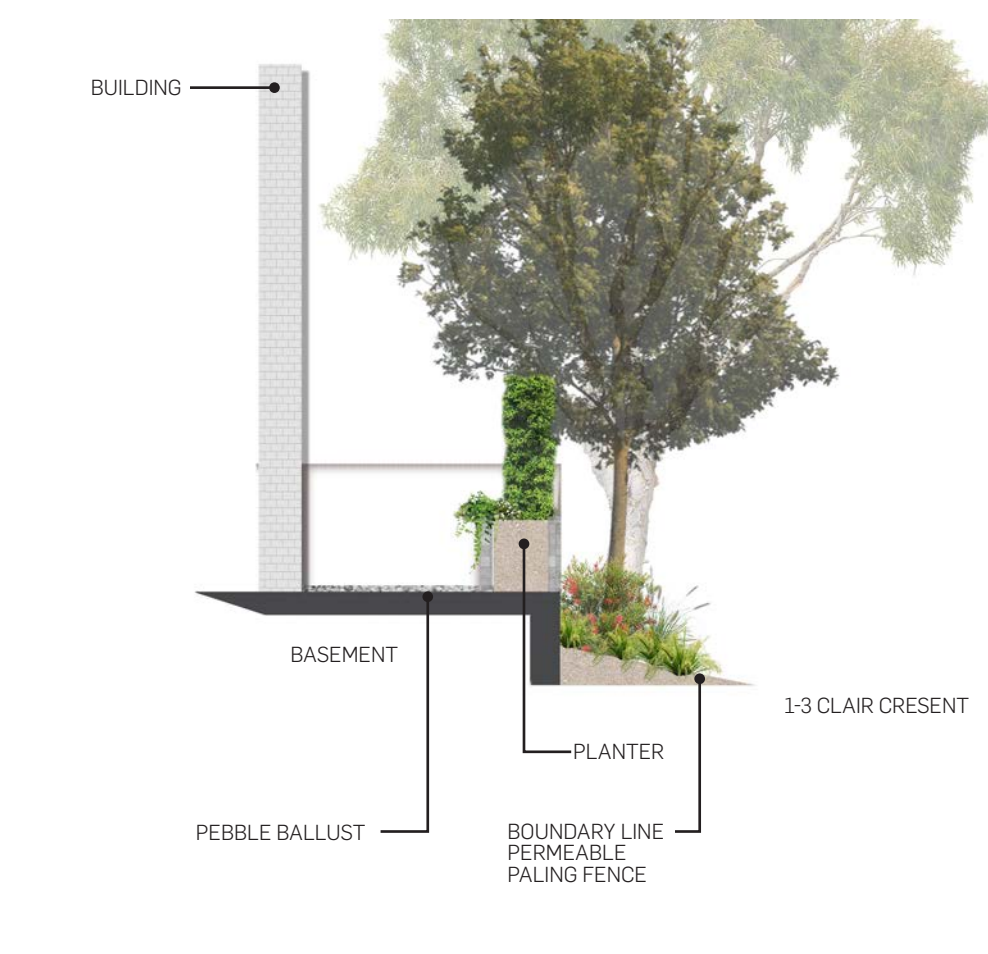

INDICATIVE SECTION (CC) OF BASEMENT 01 TERRACE

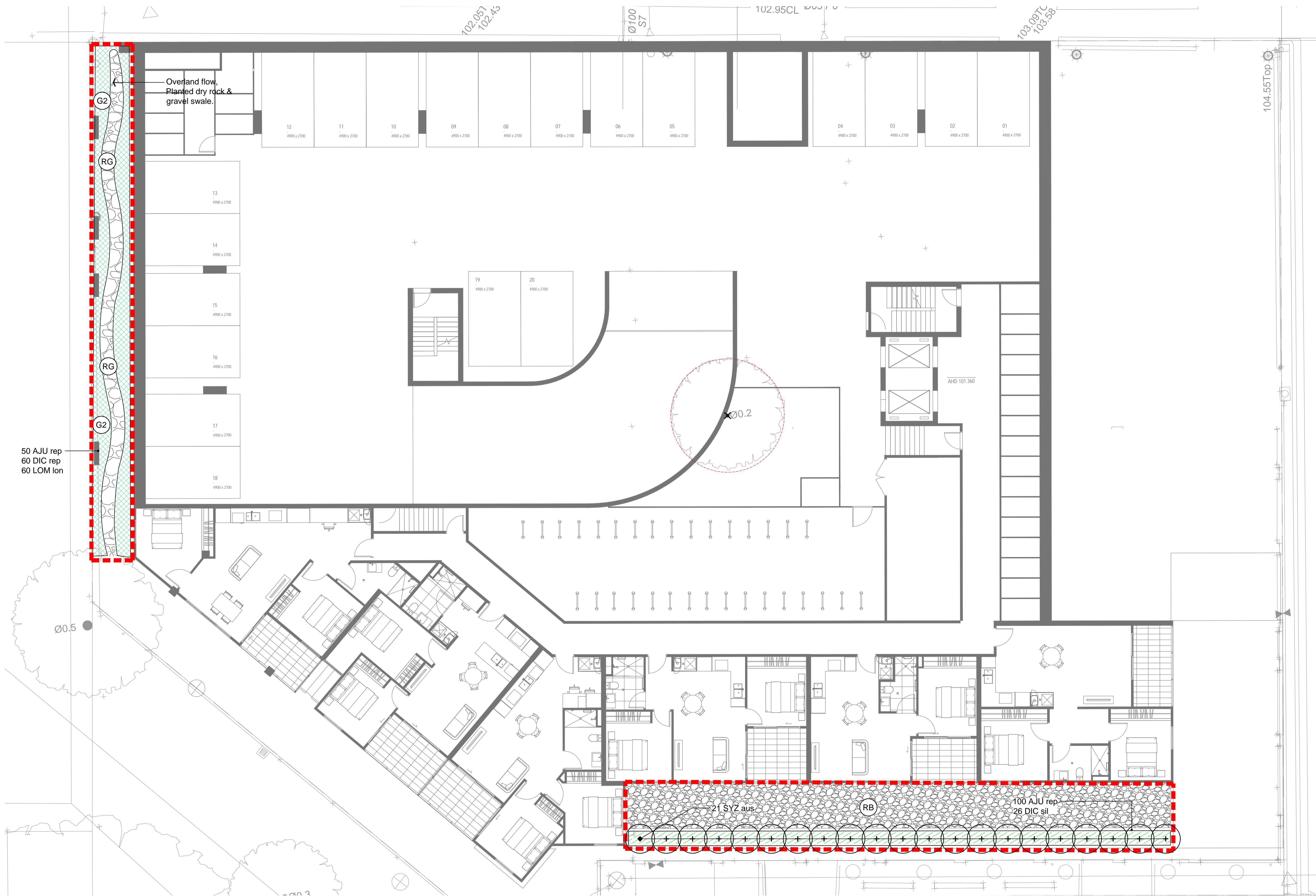

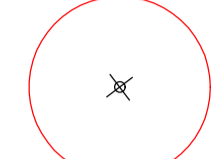

GENERAL LEGEND

-  EXTENT OF LANDSCAPE WORK
-  EXISTING TREE TO BE REMOVED

FINISHES

-  OVERLAND FLOW
PLANTED DRY ROCK SWALE
150MM DIA. ROCKS AND 20MM DIA. GRAVEL

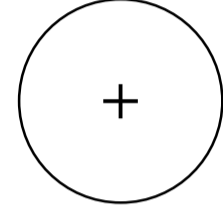
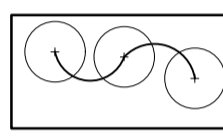
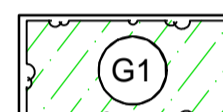
PLANTING LEGEND

-  TREE
-  SHRUBS
-  G1 : GARDEN BED PROFILE 1 (ON STRUCTURE)
-  G2 : GARDEN BED PROFILE 2 (ON GRADE)
75MM DEEP MULCH, 300MM DEEP TOPSOIL
150MM DEEP RIP SUBGRADE

GENERAL LEGEND

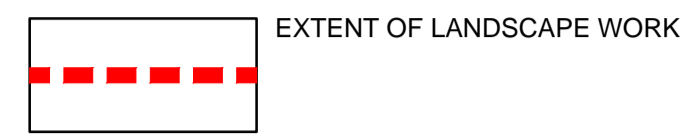

FINISHES

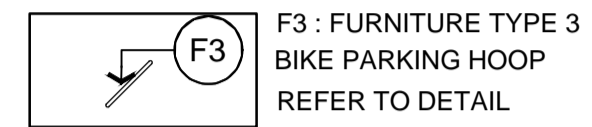
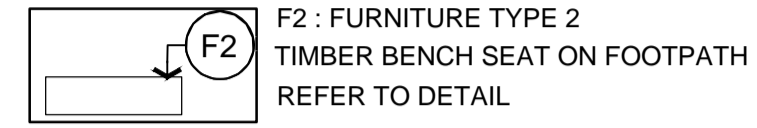

PLANTING LEGEND

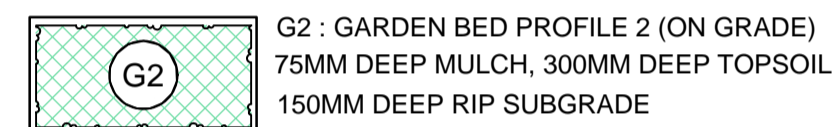
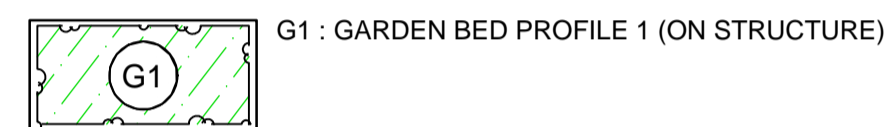
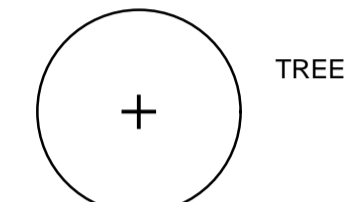

546-552 HIGH STREET ROAD

HIGH STREET ROAD

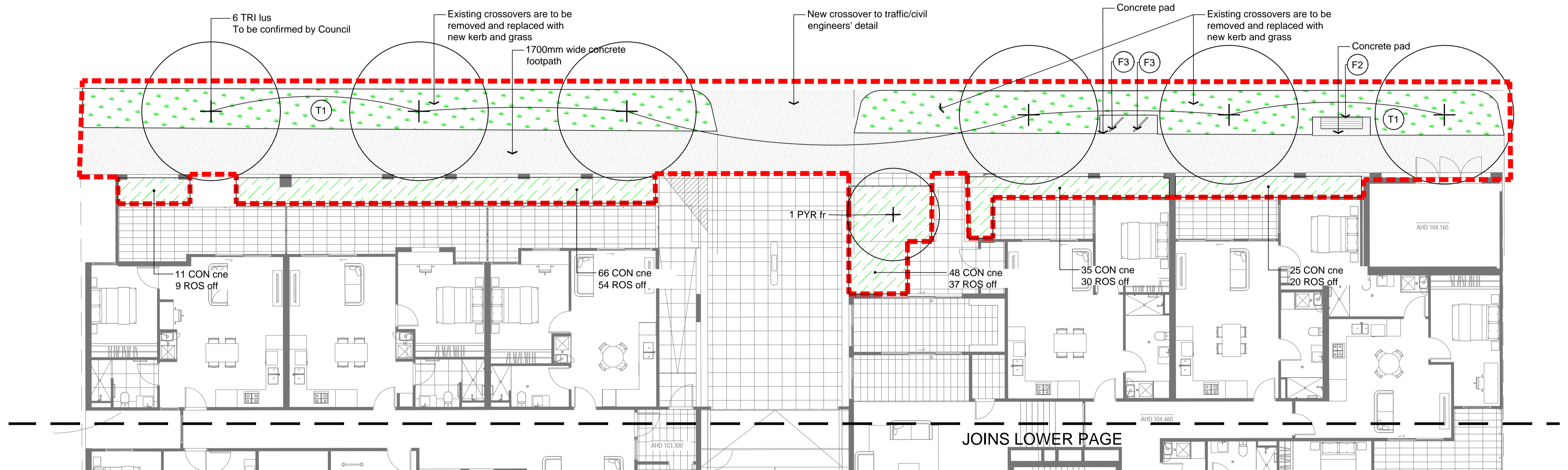



GENERAL LEGEND

EXTENT OF LANDSCAPE WORK

EXISTING TREE TO BE RETAINED

FINISHES

P1 : PAVEMENT PROFILE 1
UNIT PAVERS ON PEDESTALS

PLANTING LEGEND

TREE

SHRUBS

POTTED TREE

T1 : TURF PROFILE 1
ARTIFICIAL TURF

G1 : GARDEN BED PROFILE 1 (ON STRUCTURE)

G2 : GARDEN BED PROFILE 2 (ON GRADE)
75MM DEEP MULCH, 300MM DEEP TOPSOIL
150MM DEEP RIP SUBGRADE

MULCH
75MM DEPTH MULCH TO DEEP SOIL PLANTING

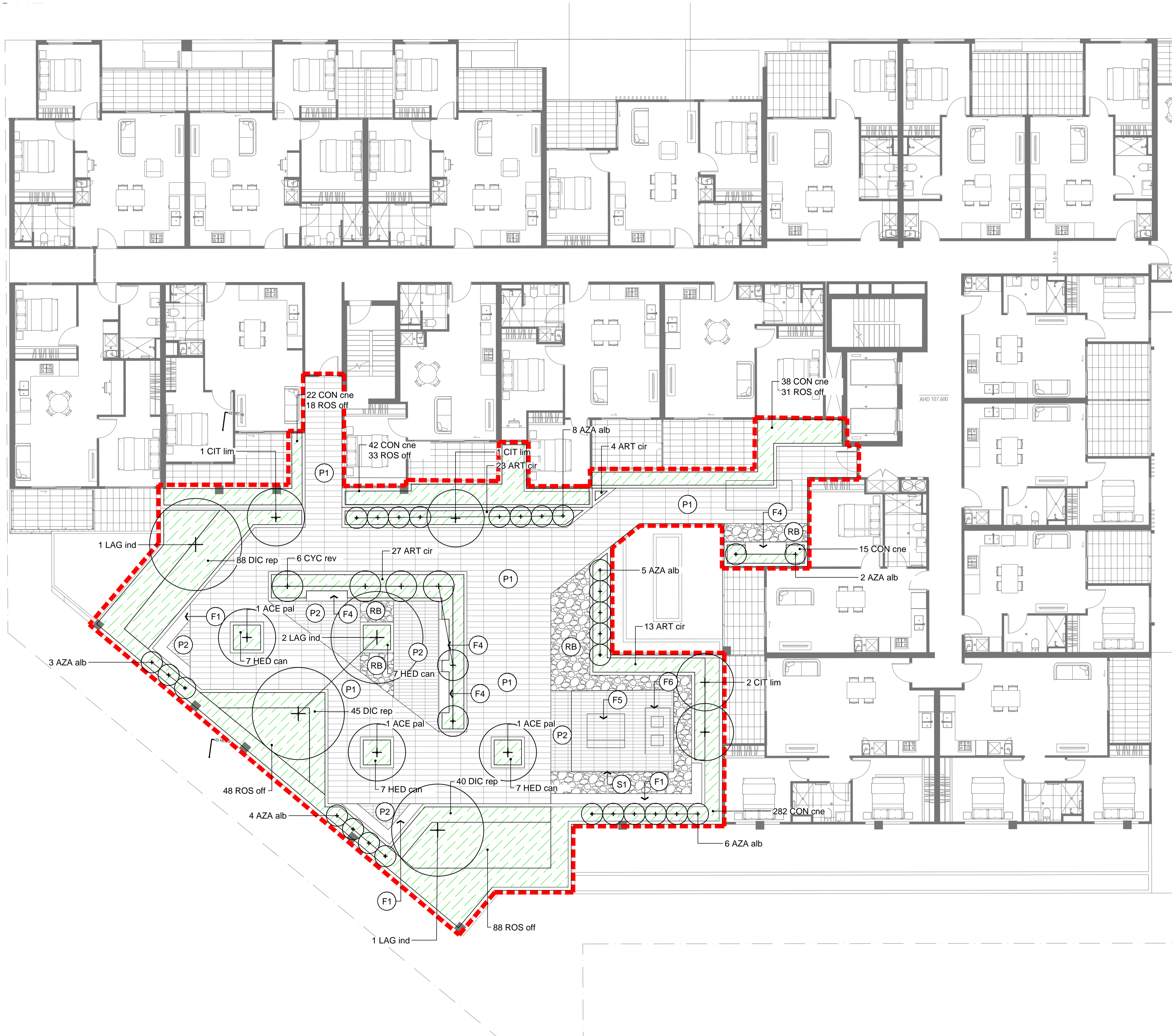

GENERAL LEGEND

[Red dashed line symbol] EXTENT OF LANDSCAPE WORK

FINISHES

- [P1 symbol] P1 : PAVEMENT PROFILE 1
UNIT PAVERS ON PEDESTALS
- [P2 symbol] P2 : PAVEMENT PROFILE 2
TIMBER DECKING ON PEDESTALS
- [RB symbol] ROCK BALLAST/ PEBBLES
TO ARCHITECTURE DETAILS
- [F1 symbol] F1 : FURNITURE TYPE 1
BUILT-IN MODWOOD TIMBER SEAT ON PODIUM LEVELS
TO BE CUSTOM DESIGNED COMPLY WITH DDA
REQUIREMENTS
- [F4 symbol] F4 : FURNITURE TYPE 4
INSITU CONCRETE SEAT WALL WITH MODWOOD TIMBER TOP
TO BE CUSTOM DESIGNED COMPLY WITH DDA REQUIREMENTS
- [F5 symbol] F5 : FURNITURE TYPE 5
PICNIC SETTING
REFER TO DETAIL
- [F6 symbol] F6 : FURNITURE TYPE 6
BBQ
REFER TO DETAIL
- [S1 symbol] S1 : STRUCTURE TYPE 1
PAGOLA STRUCTURE
CUSTOMED DESIGNED TO MEET ALL AS REQUIREMENTS

PLANTING LEGEND

- [Circle with cross symbol] TREE
- [Wavy line symbol] SHRUBS
- [Circle with cross symbol] POTTED TREE
- [Green hatched box symbol] G1 : GARDEN BED PROFILE 1 (ON STRUCTURE)

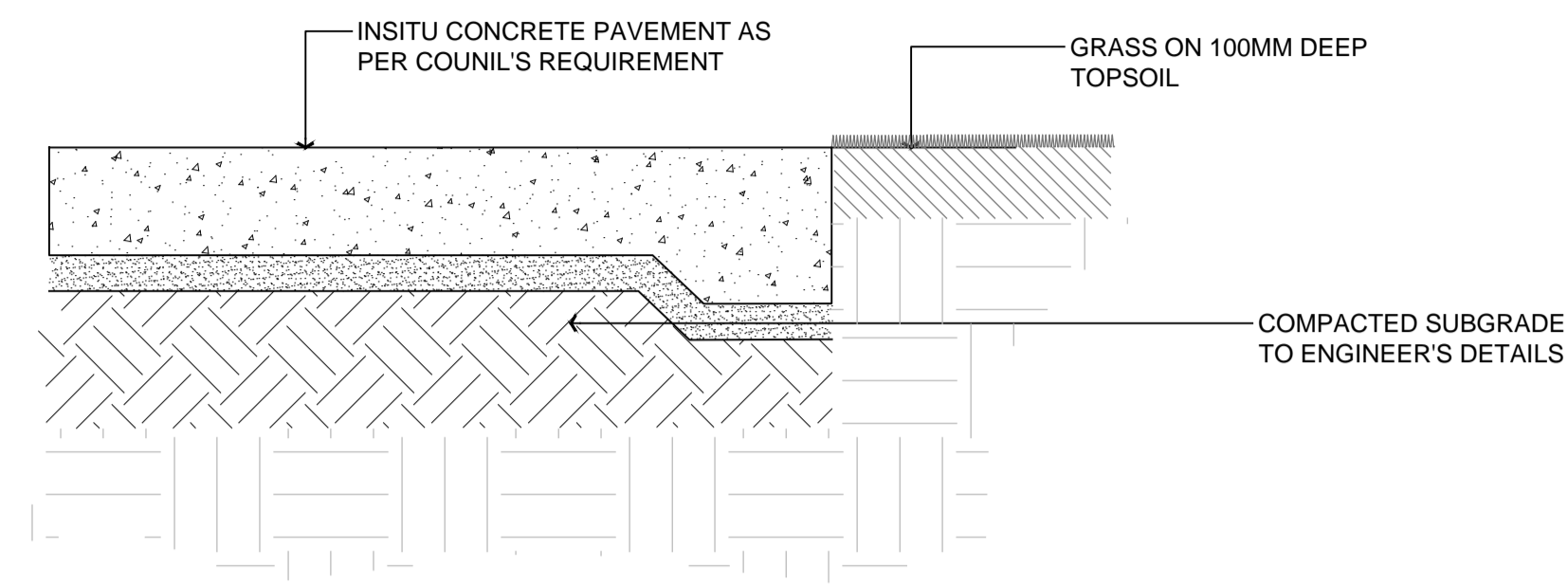

1 ON GRADE CONCRETE PATH ON NATURE STRIP DETAIL
SCALE 1:10 @ A1

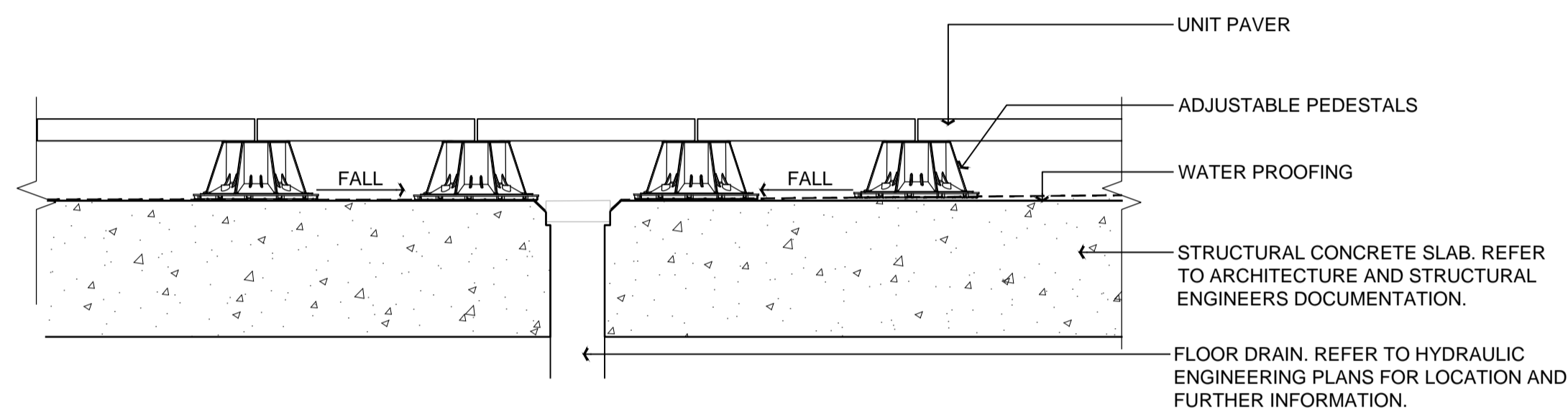

2 ON-STRUCTURE TYPICAL PAVEMENT DETAIL
SCALE 1:10 @ A1

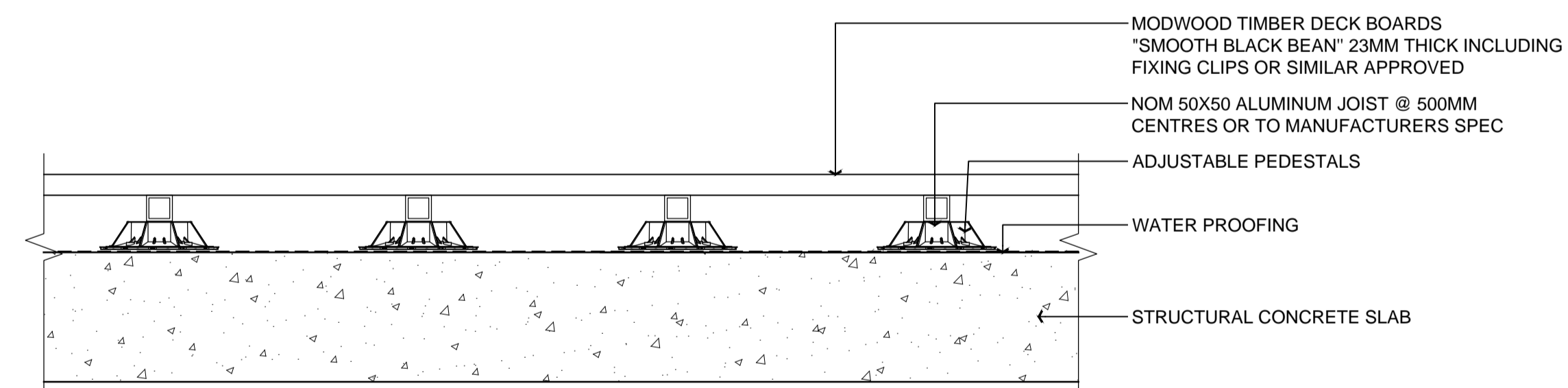

3 ON-STRUCTURE TYPICAL DECKING DETAIL
SCALE 1:10 @ A1



4 F2 - TIMBER BENCH ON FOOTPATH
(SFA, Classic Plaza DDA)

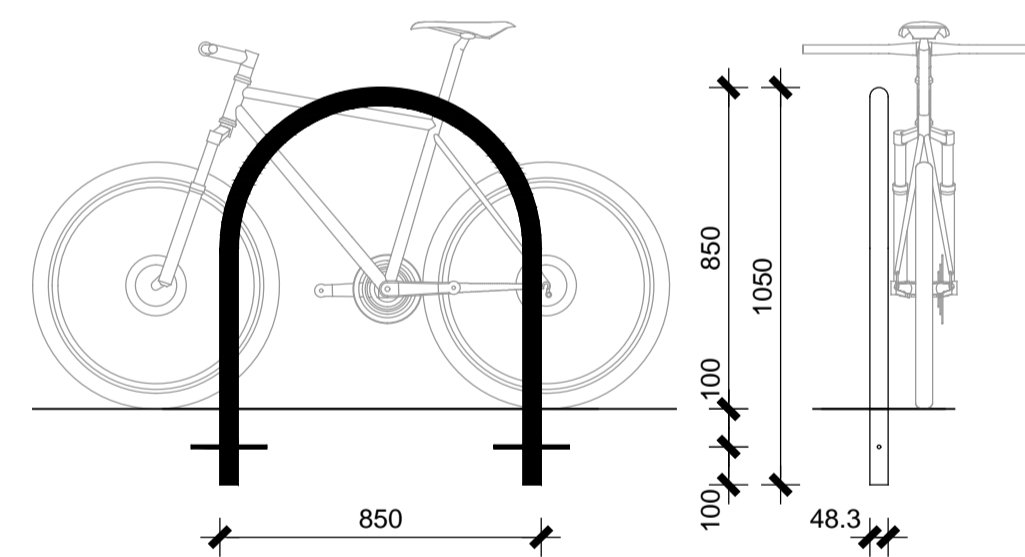
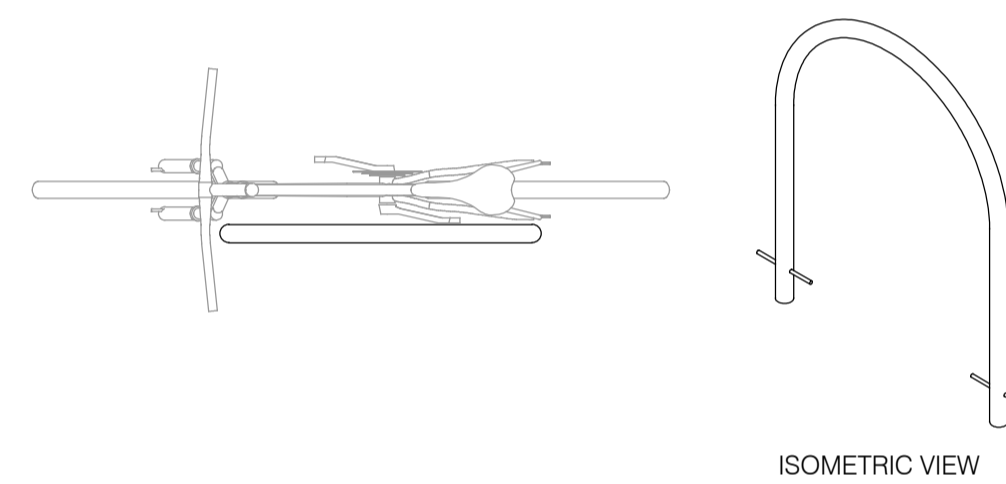

5 F3 - BIKE PARKING HOOPS
(CORA CBR2F)
SCALE 1:20

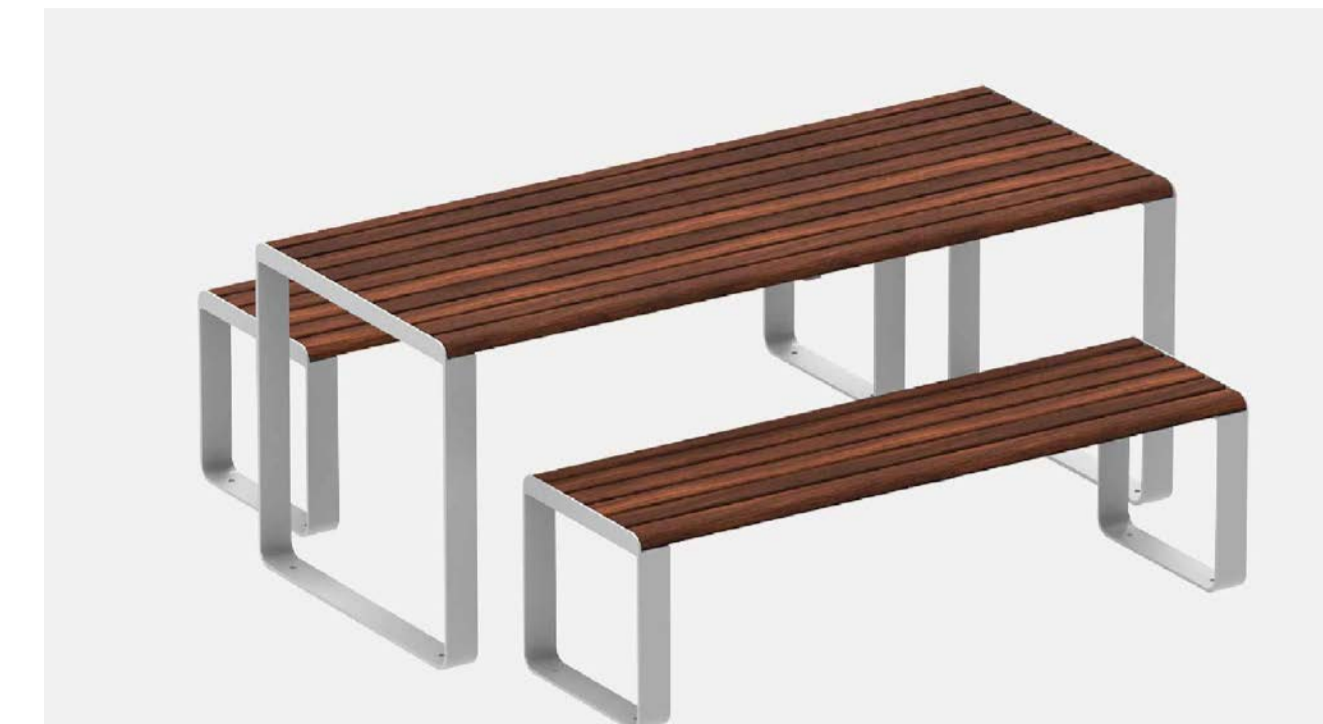

6 F5 - PICNIC SETTING
(SFA, LINEA TABLE AND BENCHES - BLACK)



7 F6 - BBQ
(GRILLEX OR SIMILAR APPROVED)





Planning Overlays and Zones

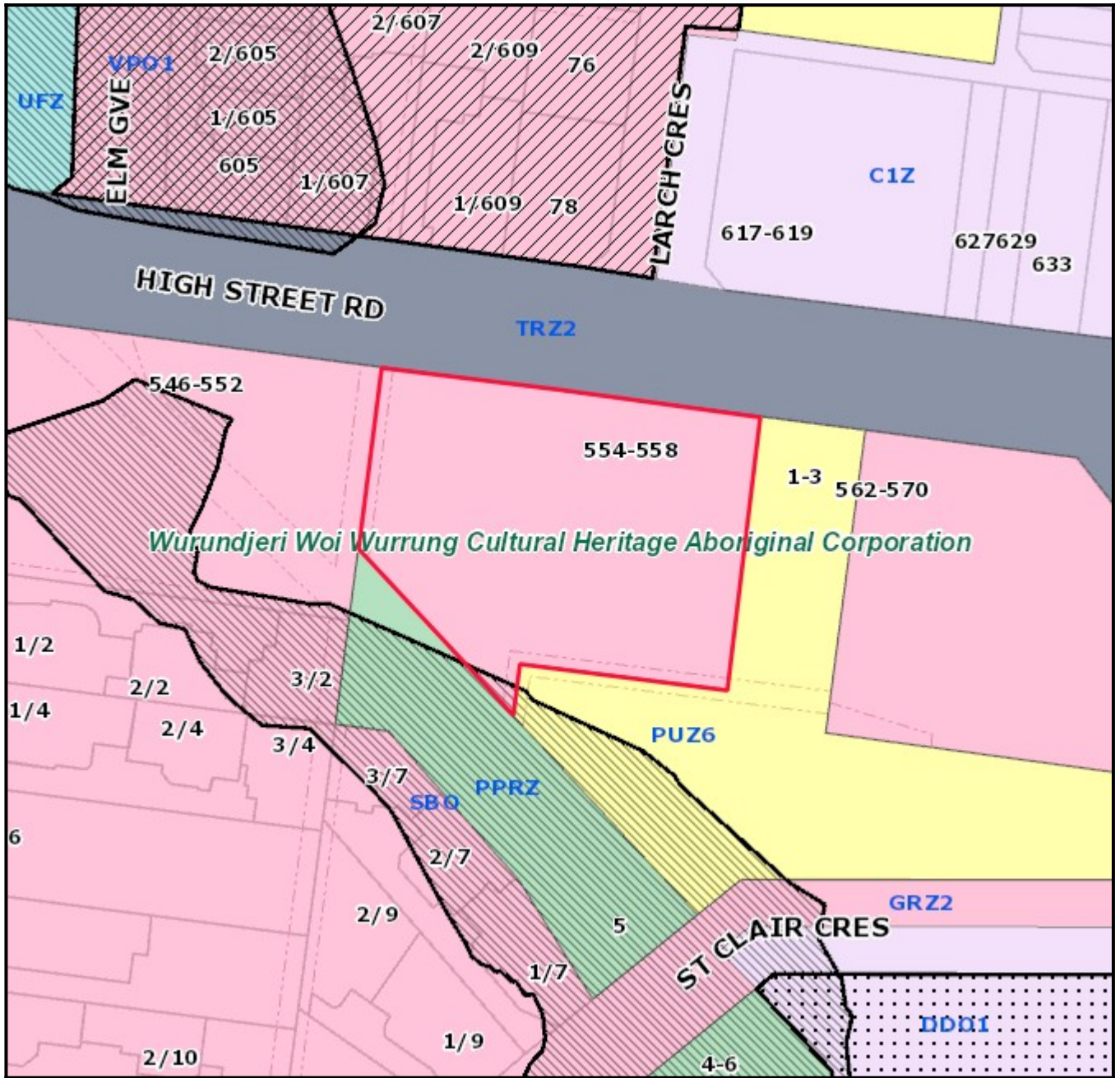

Legend

Planning Zones

Planning Overlays

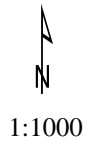

Address: 554-558 High Street Road MOUNT WAVERLEY VIC 3149

Area: 0.00000 sqm

Base data is supplied under Licence from Land Victoria. This map is for general use only and may not be used as proof of ownership, dimensions or any other status. The information must be verified before taking any action which may be affected by a planning scheme requirement. This can be done by visiting the website: <http://services.land.vic.gov.au/landchannel/content/>

The City of Monash endeavours to keep the information current, and welcomes notification of omissions or inaccuracies.

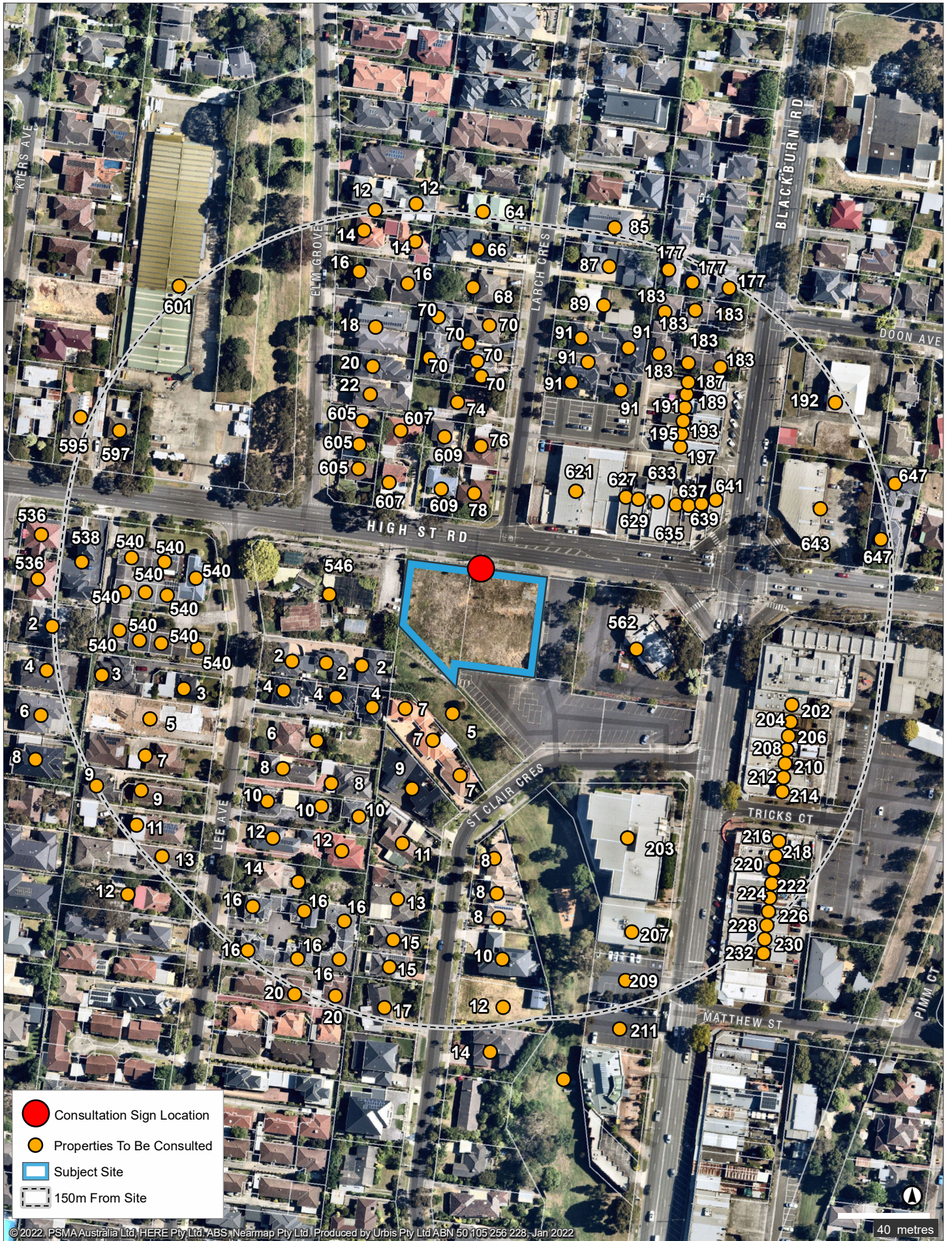

554-556 HIGH STREET ROAD, MOUNT WAVERLEY

CONSULTATION MAP